



**POTOMAC AND RAPPAHANNOCK
TRANSPORTATION COMMISSION
(PRTC)**

INVITATION FOR BIDS

IFB No. 025-002

**PRTC CEILING TILE AND GRID REMOVAL AND
REPLACEMENT**

IFB Issued: October 22, 2024

Contact: LaWana Glymph, Contract Specialist
PRTC, 14700 Potomac Mills Road, Woodbridge, VA 22192
Main Office: (703) 583-7782 Direct/Fax: (703) 583-1377 Email: lglymph@omniride.com

Contact: Cynthia Porter Johnson, Manager of Grants and Procurement
PRTC, 14700 Potomac Mills Road, Woodbridge, VA 22192
Main Office: (703) 583-7782 Direct/Fax: (703) 583-1377 Email: cporter-johnson@omniride.com

Table of Contents

I. INTRODUCTION	1
II. PROCUREMENT SCHEDULE.....	4
III. SCOPE OF WORK	5
IV. GENERAL TERMS AND CONDITIONS.....	8
V. INSTRUCTIONS TO BIDDERS.....	14
VI. ATTACHMENTS.....	18
Attachment A – Ceiling Plans	
Attachment B – Pricing Schedule	
Attachment C – Reference Form	
Attachment D – IFB Submission Form	
Attachment E – Insurance Checklist	
Attachment F – Sample Contract	

I. INTRODUCTION

I.1 Purpose of the Request

The Potomac and Rappahannock Transportation Commission (PRTC) is soliciting bids from a qualified and experienced Contractor to remove existing Ceiling Tile and Ceiling Grid and install new Ceiling Tile and Grid located at the PRTC Transit Center, 14700 Potomac Mills Road, Woodbridge, Virginia 22192.

Failure to provide all the required certifications and documents listed and described in this Invitation for Bids (IFB) may cause the bid to be rejected and be considered non-responsive.

I.2 Background Information

Located in Prince William County, about 25 miles southwest of Washington, D.C., the Potomac and Rappahannock Transportation Commission (PRTC) is a multimodal, multijurisdictional agency providing local and commuter bus services and Transportation Demand Management (TDM) services in Prince William County and the Cities of Manassas and Manassas Park. PRTC's services are operated under the OmniRide brand name and PRTC is a partner in several regional services. PRTC prides itself on providing high quality, progressive and innovative transportation services for residents of its member jurisdictions.

I.3 PRTC Contract Management:

Contract Administrator: Matters relating to prices, terms and conditions, period of performance, quantities to be supplied, delivery schedule and financial adjustments shall be handled through the Contract Administrator, LaWana Glymph, PRTC's Procurement Contract Specialist.

Project Manager: **Miranda Hellem** will serve as the Project Manager (PM) for this Contract. The PM is responsible for the technical administration of the Contract and technical liaison with the Contractor. The PM is responsible for the day-to-day clarifications and guidance of Contractor's personnel as may be required under the Contract.

Contracting Officer: PRTC's Executive Director is the only individual who can legally commit or obligate PRTC for the expenditure of federal/public funds. Only the Contracting Officer shall have the authority to revise the terms and conditions of the Contract, and any such revisions shall be authorized in writing.

Contract or Agreement: The contractual agreement between PRTC and the successful Contractor to perform work described in this solicitation and successful Contractor's bid. **Note: The Contractual instrument for this project will be PRTC's standard form Contract provided as Attachment F, modified as required to conform to this project. PRTC will not use the Bidder's form contract.**

I.4 Scope of Work

The Potomac and Rappahannock Transportation Commission (PRTC) is soliciting bids from a qualified and experienced Contractor to remove existing Ceiling Tile and Ceiling Grid and install new Ceiling Tile and Grid at the PRTC Transit Center, 14700 Potomac Mills Road, Woodbridge, Virginia 22192. The full Scope of Services for the procurement is described in **Section III – Scope of Work** in this document. The successful Bidder shall provide the means to fulfill the types of requirements listed herein.

I.5 Period of Contract

The term of this Contract will begin upon execution and all work as outlined in the Scope of Work shall be completed on or before June 30, 2025.

I.6 Type of Contract

PRTC expects to award a firm-fixed price contract for the services and materials specified in the Scope of Work to the lowest responsive and responsible bidder.

I.7 Pre-Bid Conference and Submission of Questions

An informational meeting, referred to here as a Pre-Bid Conference, will be conducted in person at PRTC Transit Center, located at 14700 Potomac Mills Road, Woodbridge, VA 22192 and virtually via Zoom on **November 5, 2024 at 11:00 AM**. Attendance is encouraged as it will assist PRTC in providing the best information on its requirements and resources to all parties.

Questions to be discussed at the meeting may be submitted as follows:

- in advance of the pre-bid conference
- orally at the pre-bid conference
- after the pre-bid conference but **no later than November 15, 2024 at 12:00 NOON**.

Questions submitted to PRTC in advance of the pre-bid conference may be sent by e-mail to lglymph@omniride.com and **must be titled "PRTC Ceiling Tile and Grid Removal and Replacement Questions."** The company posing the question must be clearly identified. PRTC will provide responses to questions via an addendum.

I.8 Posting/Notice of Award

PRTC intends to award this Contract to the lowest responsive and responsible Bidder and the PRTC Board reserves the right to reject any and all bids received, although PRTC also reserves the right to waive irregularities. Notice of Award, made as a result of this solicitation, will be made via official electronic mail and posted on the OmniRide Procurement webpage. All participants will receive email notification whether or not they are the lowest responsive and responsible Bidder and the Notice of Award to the actual lowest responsive and responsible Bidder selected.

I.9 Clarification of Terms

In order to ensure an impartial competitive process, questions, and private communications with the Prospective Bidders during bid preparation and the evaluation period will not be accepted. If a Prospective Bidder has questions about the scope of work or other solicitation documents, the Prospective Bidder should contact in writing PRTC's Contract Specialist, whose name appears on the cover page of this solicitation. Inquiries regarding this IFB will be accepted up until **November 15, 2024 at 12:00 NOON** and the inquiries together with the responses shall be distributed to all IFB recipients. Any revisions to the solicitation shall be made only by addendum issued by PRTC.

I.10 Permits and Licenses

The Contractor must be registered and licensed, as necessary, to perform the requested services in the Commonwealth of Virginia.

I.11 Emergency Order

In the event of any emergency, PRTC reserves the right to order the contracted services from other sources which could provide a faster delivery time.

II. PROCUREMENT SCHEDULE

PRTC anticipates following the procurement schedule as shown below. PRTC reserves the right to make changes to the schedule. All such changes shall be made via an addendum to the solicitation. It is the responsibility of each vendor to check the PRTC's procurement webpage (<https://omniride.com/about/business/procurement/>) or eVA, Virginia's online, electronic procurement system (<https://mvendor.cgieva.com/Vendor/public/AllOpportunities.jsp>) for information concerning this solicitation, including any addenda or notices.

October 22, 2024	IFB Issued by PRTC
November 5, 2024	Pre-bid Conference 11:00 am EST In-Person at the PRTC Transit Center, 14700 Potomac Mills Rd, Woodbridge, VA 22192 and Virtually via Zoom Facility walk-thru immediately following Pre-Bid Conference
November 15, 2024	Final Questions Due 12:00 Noon EST
November 22, 2024	PRTC Response to Questions
December 3, 2024	BIDS DUE (Bid Opening) 12:00 Noon EST
January 9, 2025	Recommend Award to PRTC Board

III. SCOPE OF WORK

III.1 Purpose

The Potomac and Rappahannock Transportation Commission (PRTC) is soliciting bids from a qualified and experienced Contractor to remove existing Ceiling Tile and Ceiling Grid and install new Ceiling Tile and Grid at the PRTC Transit Center, 14700 Potomac Mills Road, Woodbridge, Virginia 22192.

III.2 Background/Overview

- A. The existing ceiling grid and most of the ceiling tiles were installed during the original construction of the PRTC Transit Center in 1997. Over the years, tiles have been replaced individually on an as needed basis. The current condition of the ceiling grid and tiles is such that a complete replacement is needed.
- B. PRTC requests the Contractor to remove existing ceiling grid and tile and install new Armstrong 9/16 grid, or an approved equal, to all existing tiled areas on the first and second floors of the PRTC Transit Center and install new Armstrong Dune ceiling tiles, or approved equivalent in quality, texture, and thickness, to the new grid. The Contractor must obtain advance approval in writing from PRTC to install a proposed equivalent to Armstrong Dune tiles, to verify if the selected product is equivalent to the Armstrong product. Configuration shall remain the same to accommodate existing ceiling fixtures. PRTC's Ceiling Plans are provided as **Attachment A**.

III.3 General Requirements

- A. All work shall be completed Monday – Friday from 7:00 a.m. to 6:00 p.m. Any work performed outside of this period must be pre-approved by PRTC. A project timeline is required and must be agreed to in advance by PRTC.
- B. Staging for this project is important as there will be PRTC staff working on each floor throughout the project. The Contractor shall develop a plan that will keep disruptions for PRTC working staff to a minimum and obtain approval in advance from PRTC.
- C. All communication between the Contractor and PRTC shall be in writing.
- D. The ceiling height shall match current height. Ceiling shall be true, flat, straight and regular. The Contractor shall provide stabilizer bars as required to distribute load equally.
- E. The existing tie wires can remain if in suitable condition, however, any tie wires that need to be replaced, as well as any additional tie wires that are needed, are to be provided and installed

by the Contractor. PRTC staff will work with Contractor to confirm which wires should remain and/or replaced.

- F. Existing light fixtures, duct work, and sprinkler heads are to remain in current configuration.
- G. All work shall be done in a manner of workmanship that shall reflect full journeyman capabilities in the required trade and meet industry standards.

III.4 Contractor Responsibilities are listed below, but not limited to, the following:

- A. The Contractor is responsible for all material, supplies, supervision, equipment, labor, and testing needed to complete the project in a professional manner.
- B. The Contractor shall install maximum lengths of edge moulding at the intersection of ceiling and vertical surface and miter all corners.
- C. All perimeter moulding is to be flat angle moulding, typical, and is to be white in color.
- D. Any tegular ceiling tile is to be cut and fitted snug against partitions. Do not shim the grid to allow ceiling tile to pass over top of partition.
- E. Level ceiling to within 1/8" in 12 feet in any direction, level with hanger wire taut and plumb, without kinking or bending hanger wires.
- F. The Contractor shall field check the premises and verify that the ceiling layout is correct and verify all clearances as required.
- G. All fixture trim (lighting, speaker, HVAC grilles, etc.) shall be metal and painted to match adjacent ceiling finish. Do not use plastic trim.
- H. The Contractor shall provide protection for existing finishes. All surfaces shall be covered prior to demolition and during installation. All necessary furniture shall be moved as needed during removal and installation by the Contractor. All furniture moved during ceiling tile removal and installation shall be returned to the original location after work is completed.
- I. Upon completion of each area, complete construction cleanup is required to bring the space back to original cleanliness.
- J. The Contractor is responsible for the removal of all trash, materials and/or debris generated on a daily basis.
- K. Any damage incurred during this project that was not documented before work was started will be repaired by the Contractor at no additional cost.

- L. The Contractor is responsible for securing all required permits prior to starting the project.
- M. The Contractor is responsible for arranging all necessary inspections.
- N. The Contractor is responsible for maintaining a safe construction site and complying with all OSHA, State, and local regulations.
- O. The Contractor shall provide a quantity of forty-eight (48) ceiling tiles of the same as used for installation to be used for future replacements.

IV. GENERAL TERMS AND CONDITIONS

IV.1 Bid and Contract Requirements

This IFB plus the resulting bid and contract shall be consistent with and governed by the Virginia Public Procurement Act, Va. Code §§ 2.2-4300 *et seq.* In the event of an inconsistency between the solicitation and the selection requirements set forth in this IFB versus those set forth in the Virginia Public Procurement Act, the inconsistency shall be resolved by giving precedence to the solicitation and selection requirements of the Virginia Public Procurement Act.

PRTC will provide a contract for execution by the Successful Contractor – a sample contract containing these provisions is included as **Attachment F**. Successful Contractors will not use their own standard contracts for this engagement.

IV.2 Obligation of Prospective Contractor

By submitting a bid, the Prospective Contractor agrees that it has satisfied itself from a personal investigation of the conditions to be met, that the obligations herein are fully understood, and no claim may be made, nor will there be any right to cancellation or relief from the Contract because of any misunderstanding or lack of information.

IV.3 Qualification of Bidders

The Prospective Contractor must demonstrate to the satisfaction of PRTC that it has the necessary experience, skilled personnel, and financial resources to perform the services required under this solicitation. Qualified contractors shall have substantial recent experience in providing similar services on a scale equal to or greater than what PRTC is requesting and meet the following requirements:

- Receive high praise from past clients for quality of work, timely delivery, and fair and equitable handling of change orders.
- Employ, or have the ability to hire, the necessary complement of personnel to complete all work in the specified time.

PRTC may make such reasonable investigations as deemed proper and necessary to determine the competency and financial stability of the Bidder to perform the contract. The Bidder shall furnish to PRTC such information and data for this purpose as may be requested. PRTC reserves the right to inspect the Prospective Contractor's physical plant prior to award to satisfy questions regarding the Prospective Contractor's capabilities.

If, after the investigation, the evidence of competency and financial stability is not satisfactory, in the sole opinion of PRTC, PRTC reserves the right to reject the bid.

IV.4 Additional Information

PRTC reserves the right to ask any Prospective Contractor to clarify its offer.

IV.5 Qualification Acceptance Period

The bid and any modification thereof shall be binding upon the Prospective Contractor for 90 calendar days following the bid due date. Any bid for which the Prospective Contractor shortens the acceptance period may be rejected. At the end of that time, the Prospective Contractor may retract its bid by giving written notice to PRTC.

IV.6 Delays in Award

Delays in award of a contract, beyond the anticipated starting date, may result in a change in the contract period indicated in the solicitation. If this situation occurs, PRTC reserves the right to award a contract covering the period equal to or less than the initial term indicated in the solicitation.

IV.7 Award for All or Part

Unless otherwise specified, PRTC may, if it is in the best interest of PRTC to do so, award all or part of the bid to any Prospective Contractor whose bid is the most responsible and responsive and whose bid meets the requirements and criteria set forth in the Request for Bid with respect to the items in question.

IV.8 Rejection of Bids

PRTC expressly reserves the right to reject any or all bids or any part of a bid, and to re-solicit the services in question, if such action is deemed to be in PRTC's best interest. PRTC will not compensate Bidders for the cost of bid preparation whether or not an award is consummated.

IV.9 Single Bid

If a single conforming bid is received, a price and/or cost analysis of the Bid shall be made by PRTC. A price analysis is the process of examining and evaluating a prospective price without evaluation of the separate cost element. It should be recognized that a price analysis through comparison to other similar contracts should be based on an established or competitive price of the elements used in the comparison. The comparison shall be made to the cost of similar projects and involve similar specifications.

IV.10 Inspection of Bids

The Virginia Freedom of Information Act, §§ 2.2-3700 *et seq.* shall govern the release of public records related to the Contract. Trade secrets or proprietary information related to procurement

may not be subject to public disclosure, provided the requirements at Va. Code § 2.2-4342.F. are met.

IV.11 Protest of Award

A Prospective Contractor who wants to protest an award or a decision to award a contract must submit the protest, in writing, to PRTC no later than 10 days after either the decision to award or the award, whichever occurs first. The protest must include the basis for the protest and the relief sought. Within 10 days after receipt of the protest, the Executive Director of PRTC will issue a written decision stating the reasons for the action taken. This decision is final. Further action, by a Prospective Contractor, may be taken by instituting action as provided by the Code of Virginia.

IV.12 Protest Policy

PRTC policy and procedure for the administrative resolution of protest is set forth in §3.8 of the PRTC/VRE Public Procurement Policy and Procedures Manual (Procurement Manual). The Procurement Manual contains rules for the filing and administration of protests. The Contract Administrator shall furnish a copy of §3.8 upon request.

IV.13 Debarment Status

The Commonwealth Transportation Board's Policy of Debarment, dated January 1, 1987, shall apply with the exception that the debarment period shall be for a period of up to thirty-six (36) months. By submitting a bid, the Prospective Contractor certifies that it is not currently debarred from submitting bids on contracts by any agency of the Commonwealth of Virginia, nor is an agent of any person or entity that is currently debarred from submitting bids or contracts by any agency of the Commonwealth of Virginia.

IV.14 Anti-Discrimination

By submitting a bid, the Prospective Contractor certifies to PRTC that it will conform to the provisions of Title VI of the Federal Civil Rights Act of 1964, as amended; DOT regulations, "Nondiscrimination in Federally-Assisted Programs of the Department of Transportation" -- Effectuation of Title VI of the Civil Rights Act; the Virginia Fair Employment Act of 1975, as amended, where applicable; all requirements of Title VIII of the Civil Rights Act of 1964, as amended, 42 U.S.C. § 20003, and 49 U.S.C. § 4332 and any implementing requirements FTA may issue; the provisions of 49 U.S.C. § 5332, "Nondiscrimination in Federal Transit Programs," which prohibits discrimination on the basis of race, color, creed, national origin, sex, or age, and prohibits discrimination in employment or business opportunity; and Va. Code § 2.2-4311 of the Virginia Public Procurement Act.

IV.15 Insurance

PRTC will require the Contractor to purchase and maintain insurance coverage to the levels described in this section. A description of the proposed insurance as specified below, including

insurance carrier names and policy numbers, should be included in the Bidder's technical bid. The cost of insurance should be shown by line of coverage.

A checklist of required insurance coverage is attached and identified as Insurance Checklist (**Attachment E**). Items marked "X" are required to be provided. If such insurance is incomplete, provide a letter from your insurance agent stating that the Bidder is eligible to obtain insurance to the prescribed limits should a Contractual offer be extended.

PRTC may require that insurance be raised due to change orders to this Contract and/or execution of "Options." At no time shall the insurance coverage be less than required.

The Successful Contractor agrees to include the provisions of the foregoing clause in every subcontract or purchase order so that the provisions shall be binding upon each subcontractor or vendor.

In addition to the terms and provisions set forth above, the Successful Contractor shall be required to provide evidence of the minimum coverage described in **Attachment E**, Insurance Checklist. No contract shall be finalized, and no work shall commence until PRTC's insurance requirements are met. The Successful Contractor shall comply with the insurance requirements set forth in the following numbered paragraphs, plus the coverage and limits indicated on **Attachment E**, Insurance Checklist. Technical proposals must note any desired exceptions to the insurance coverage, which may include the submission of proposed alternatives.

a. The firm shall be responsible for its work and every part thereof, and for all materials, equipment, and property of any and all description used in connection therewith. The firm assumes all risks of direct and indirect damage or injury to any person or property wherever located, resulting from any action, omission, commission, or operation under the contract, or in connection in any way whatsoever with the contracted work.

b. The firm shall, during the continuance of all work under the contract provide and agree to maintain the following unless omitted from the attached "Insurance Checklist":

i. Workers' Compensation and Employers' Liability insurance under the Commonwealth of Virginia statutory requirements, to protect the firm from any liability or damages for any injuries (including death and disability) to any and all of its employees, volunteers, or subcontractors, including any and all liability or damage which may arise by virtue of any statute or law in force within the Commonwealth of Virginia, or which may be hereinafter enacted.

ii. General Liability insurance in the amount prescribed by PRTC, to protect the Contractor, its subcontractors, and the interest of PRTC, against any and all injuries to third parties, including bodily injury and personal injury, wherever located, resulting from any action or operation under the Contract or in connection with the contracted work. The General Liability insurance shall also include the Broad Form General Liability endorsement, in addition to

coverage for explosion, collapse, and underground hazards, where required. Completed Operations Liability coverage shall continue in force for one year after completion of work.

iii. Automobile Liability insurance, including property damage, covering all owned, non-owned, borrowed, leased, or rented vehicles operated by the Successful Contractor. In addition, all mobile equipment used by the Successful Contractor in connection with the contracted work shall be insured under either a standard Automobile Liability policy, or a Commercial General Liability policy.

c. Liability insurance may be arranged by General Liability and automobile Liability policies for the full limits required, or by a combination of underlying Liability policies for lesser limits with the remaining limits provided by an Excess or Umbrella Liability policy.

d. The Successful Contractor agrees to provide insurance issued by companies admitted within the Commonwealth of Virginia, with the Best's Key Rating of at least A: VI.

e. The Successful Contractor will provide an original, signed Certificate of Insurance, showing PRTC as an additional insured, evidencing such insurance and such endorsements as prescribed herein, and shall have it filed with the PRTC Executive Director before a contract is executed and any work is started.

f. The Successful Contractor will secure and maintain all insurance policies of its subcontractors, which shall be made available to PRTC on demand.

g. The Successful Contractor will provide on demand, certified copies of all insurance coverage on behalf of the Contract within ten (10) business days of demand by PRTC. These certified copies shall be sent to PRTC from the Contractor's insurance agent or representative.

h. No change, cancellation, or non-renewal shall be made in any insurance coverage without a 30-day written notice to the PRTC Executive Director. The Successful Contractor shall furnish a new certificate prior to any change or cancellation date. The failure of the Contractor to deliver a new and valid certificate will result in suspension of all payments until the new certificate is furnished to the PRTC Executive Director.

i. Insurance coverage required in these specifications shall be in force throughout the Contract term. Should the Successful Contractor fail to provide acceptable evidence of current insurance within five days of written notice at any time during the Contract term, PRTC shall have the absolute right to terminate the Contract without any further obligation to the Successful Contractor, and the Successful Contractor shall be liable to PRTC for the entire additional cost of procuring the incomplete portion of the Contract at time of termination.

j. Compliance by the Successful Contractor and all subcontractors with the foregoing requirements as to carrying insurance shall not relieve the Successful Contractor and all subcontractors of their liabilities and obligations under this hearing or under any other section or provisions of the Contract.

- k. Contractual and other Liability insurance provided under the Contract shall not contain a supervision, inspection, or services exclusion that would preclude PRTC from supervising and/or inspecting the project as to the end result. The Successful Contractor shall assume all on-the-job responsibilities as to the control of persons directly employed by it and of the subcontractors and any person employed by the subcontractor.
- l. Nothing contained herein shall be construed as creating any contractual relationship between the subcontractor and PRTC. The Successful Contractor shall be as fully responsible to PRTC for the acts and omissions of the subcontractors and of persons employed by them as it is for acts and omissions of persons directly employed by it.
- m. Precaution shall be exercised at all times for the protection of persons (including employees) and property.
- n. The Successful Contractor and all subcontractors and sub-subcontractors shall comply with the Occupational Safety and Health Act of 1970, Public Law 91-956, as it may apply to the Contract.
- o. If the Successful Contractor does not meet the specifications of these insurance requirements, alternate insurance coverage, satisfactory to the PRTC Executive Director, may be considered.
- p. PRTC shall be named an additional insured in the General Liability policies and stated so on the Certificate.

V. INSTRUCTIONS TO BIDDERS

V.1. General

The following general information is provided to all bidders to facilitate the preparation of suitable bids for the goods or services identified in this IFB, and the requirements set forth shall be binding on all bidders.

Bids must be based on the entire bid set and nothing else, and bidders are expected to take into consideration that the bid set, including any contract which is a part of the Invitation, will constitute the terms of the bargain between PRTC and the successful bidder. Where a contract is provided, it is intended that it shall incorporate the terms and conditions of the bid, rendering further reference to the bid set unnecessary.

PRTC is not at liberty to change the terms of the bargain after the opening of bids. Where questions and discussions prior to bid opening disclose a need for additional information or amendments, appropriate addenda to the IFB will be prepared and distributed so that all bidders will be offering price quotes based on the same information and specifications.

The PRTC Executive Director may extend the date and time for opening of bids if he believes it is necessary.

V.2 Bid Format

One (1) copy of the Bid Submission Package including the required forms must be returned.

The Bid Submission Package should include the following:

- a. Title Page – show the name of the Bidder’s firm, local address, telephone number, name of contact person and date.
- b. Letter of Transmittal summarizing the bid and noting exceptions (if any).
- c. A written statement giving the name and address of all proposed subcontractors, the portion of the work and materials which the proposed subcontractors are to perform and any other information which indicates the proposed subcontractors have the necessary facilities, skills, integrity, past experience and financial resources to perform the work.
- d. Required Bid Submission Forms as listed below:
 1. Pricing Schedule (**Attachment B**)
 2. Reference Form (**Attachment C**)

3. IFB Submission Form (**Attachment D**)
4. Insurance Checklist and Bidder & Insurance Agent Statement (**Attachment E**)

Additionally, Bidders may submit other materials describing their company, qualifications, etc.

Vendors can respond to PRTC's solicitations by submitting bids and proposals in paper and also in electronic format, using the Commonwealth of Virginia electronic procurement portal. eVA is Virginia's online, electronic procurement system. Paper bids shall be submitted in a sealed package which clearly identifies the Project or procurement name, the name of the bidder, the due date and time of the bid opening and plainly states that the bid is not to be opened until bid opening. The bidder assumes the risk that an envelope not properly marked will be mistakenly opened, and thus may be rendered ineligible for consideration. The PRTC Executive Director or his representative(s) shall not be responsible for the premature opening of a bid not properly addressed and identified as specified herein.

V.3 Completeness

All information required by the IFB must be supplied in order for the bid to be considered complete. Inadequate information may require disqualification of the bid. Bids cannot ordinarily be modified after they are opened. Any modifications not expressly provided for in the Invitation may require rejection of the bid.

V.4 Net Prices

Bid prices, unless otherwise specified, must be net, including transportation and handling charges fully prepaid by the contractor to destination, and subject only to any discount for prompt payment that may be provided in this Invitation.

V.5 Tax Exemption

PRTC is exempt from the payment of any Federal excise or any Virginia sales tax. However, when under established trade practice any Federal excise tax is included in the list price, the bidder may quote the list price and shall show separately the amount of Federal tax, as a flat sum, which shall be deducted by PRTC.

V.6 Only Authorized Parties to Sign

Each bid, and any contract, must be signed by a person authorized to bind the bidder to a valid Contract with PRTC. The PRTC Executive Director may require that any bidder submit powers of attorney or other appropriate documentation showing the authority of the signature to act on the Contractor's behalf. If, whether such proof of agency has been

demanded or not, it later appears that the signatory was not authorized to act, PRTC may declare the Contract void if it is in its best interests to do so.

V.7 Time for Submission of Bids

Written sealed bids for the goods or services identified must be submitted not later than the date and time set forth elsewhere in this IFB.

V.8 Return of Bid Package

If a prospective Bidder is unable to submit a bid in response to this IFB, the bidder should return the IFB with a statement as to why the bidder is unable to bid. Because of the large number of firms listed on PRTC's qualified list of bidders, it is necessary to delete from these lists the names of those persons, firms or corporations who fail to respond after having been invited to bid on three successive solicitations. Furthermore, PRTC is interested in learning whether problems with the bid process have discouraged responses.

V.9 Bidders Present

Contents of bids (price schedule) will be made public at the time fixed for the opening of bids. Bidders are strongly encouraged to attend all openings, and to offer constructive suggestions for improvements to bid procedures, format, or other matters.

V.10 Evaluation of Bids

Bids shall be evaluated on the basis of those requirements which are set forth in the IFB, the Specifications, and the requirements of these General Provisions, any Special Provisions, and the Virginia Public Procurement Act. Bids shall be awarded to the lowest responsive and responsible bidder as set forth in Va. Code § 2.2-4318.

V.11 Competency of Bidder

No bid will be accepted from, or contract awarded to any person, firm, or corporation that is in arrears, or is in default to PRTC upon any debt or contract, or that has defaulted as surety or otherwise upon any obligation to PRTC. The bidder, if requested, must present within forty-eight (48) hours evidence satisfactory to the PRTC Executive Director of performance ability, and possession of necessary facilities, pecuniary resources, and adequate insurance to comply with the terms of these Specifications and contract documents.

V.12 Waiver of Informalities or Irregularities

The PRTC Executive Director is authorized to waive any irregularity or informality in any bid; provided, however, bids or amendments which are received after the time specified for the opening of bids will be neither opened nor considered.

V.13 Withdrawals of Bids

Withdrawal of bids is strictly governed by Va. Code § 2.2-4330. If a bid may be lawfully withdrawn under that section, notice of withdrawal must be provided in writing within two (2) business days after the bid opening.

V.14 One Responsive and Responsible Bid

When only one responsive and responsible bid is received, the IFB may be cancelled and items rebid, unless the PRTC Executive Director determines the price bid is reasonable and in the best interests of PRTC, on the basis of price comparison, value analysis, prior price history, an engineering estimate, or other method which establishes the reasonableness of the price bid.

When the PRTC Executive Director personally determines that the above methods of establishing price reasonableness are not feasible, he may enter into negotiations with the single responsible and responsive bidder. Such negotiations shall consist of detailed discussions with regard to the cost of labor, materials, overhead and profit. The PRTC Executive Director shall establish a detailed cost/price objective that he determines to be in the best interest of PRTC, prior to the initiation of negotiations.

Any bidder who is a party to such negotiations shall be required to certify that its price proposal is complete, current, and accurate prior to the initiation of such negotiations.

A record of negotiations shall be prepared upon the completion thereof, which shall detail the most significant considerations which resulted in the agreed upon Contract price.

V.15 Cancellation of the Invitation for Bid

Virginia Code § 2.2-4319, permits the PRTC Executive Director to cancel any solicitation if it is in the best interest of PRTC to do so.

Bids received at PRTC after the date and time prescribed will not be considered for Contract award and will be returned to the Bidder. The names of the Bidders submitting bids will be available after the bid closing time and date.

VI. ATTACHMENTS

ATTACHMENT A – CEILING PLANS

ATTACHMENT B – PRICING SCHEDULE

ATTACHMENT C - REFERENCE FORM

ATTACHMENT D - IFB SUBMISSION FORM

ATTACHMENT E - INSURANCE CHECKLIST

ATTACHMENT F – PRTC SAMPLE CONTRACT

**ATTACHMENT A
PRTC CEILING PLANS**

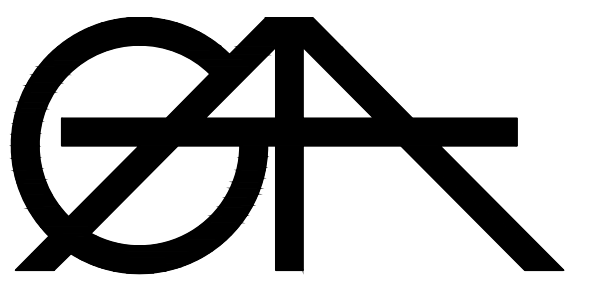

Gauthier, Alvarado & Associates, Inc.

Architecture Engineering Planning

PROJECT TITLE

PRTC

POTOMAC AND RAPPAHANNOCK
TRANSPORTATION COMMISSION

MULTI-PURPOSE TRANSIT CENTER

TRANSPORTATION CONSULTANTS:
SG Associates, Inc.

SITE ENGINEERS:
Springfield Engineering
Corporation, P.C.

PLANNING LANDSCAPE AND
SIGNAGE CONSULTANTS:
Coffin & Coffin

REVISIONS

NO.	DATE	DESCRIPTION
6	5-2-97	ADD INT OFFICES
7	6-20-97	REVISION TO OFFICES
8	8-18-97	REVISION TO OFFICES
	7-20-98	RECORD DWGS

DRAWN PS

CHECKED KD

DRAWING TITLE

ARCHITECTURAL FIRST & SECOND FLOOR CEILING PLANS-PART A

DATE 1-15-96

DRAWING NUMBER

A-9

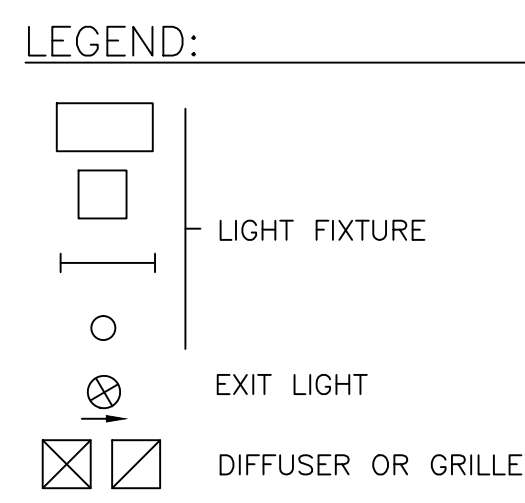
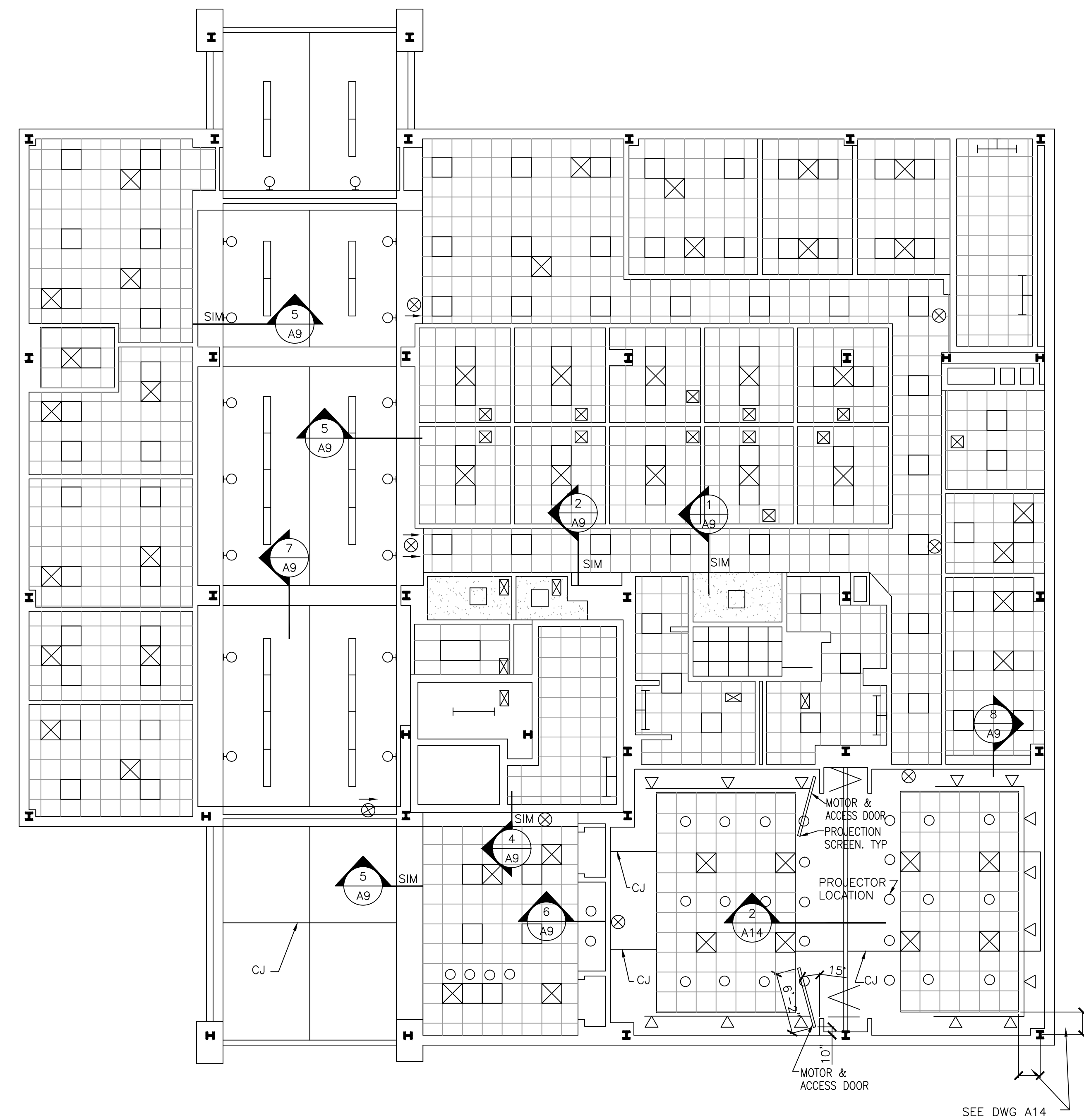
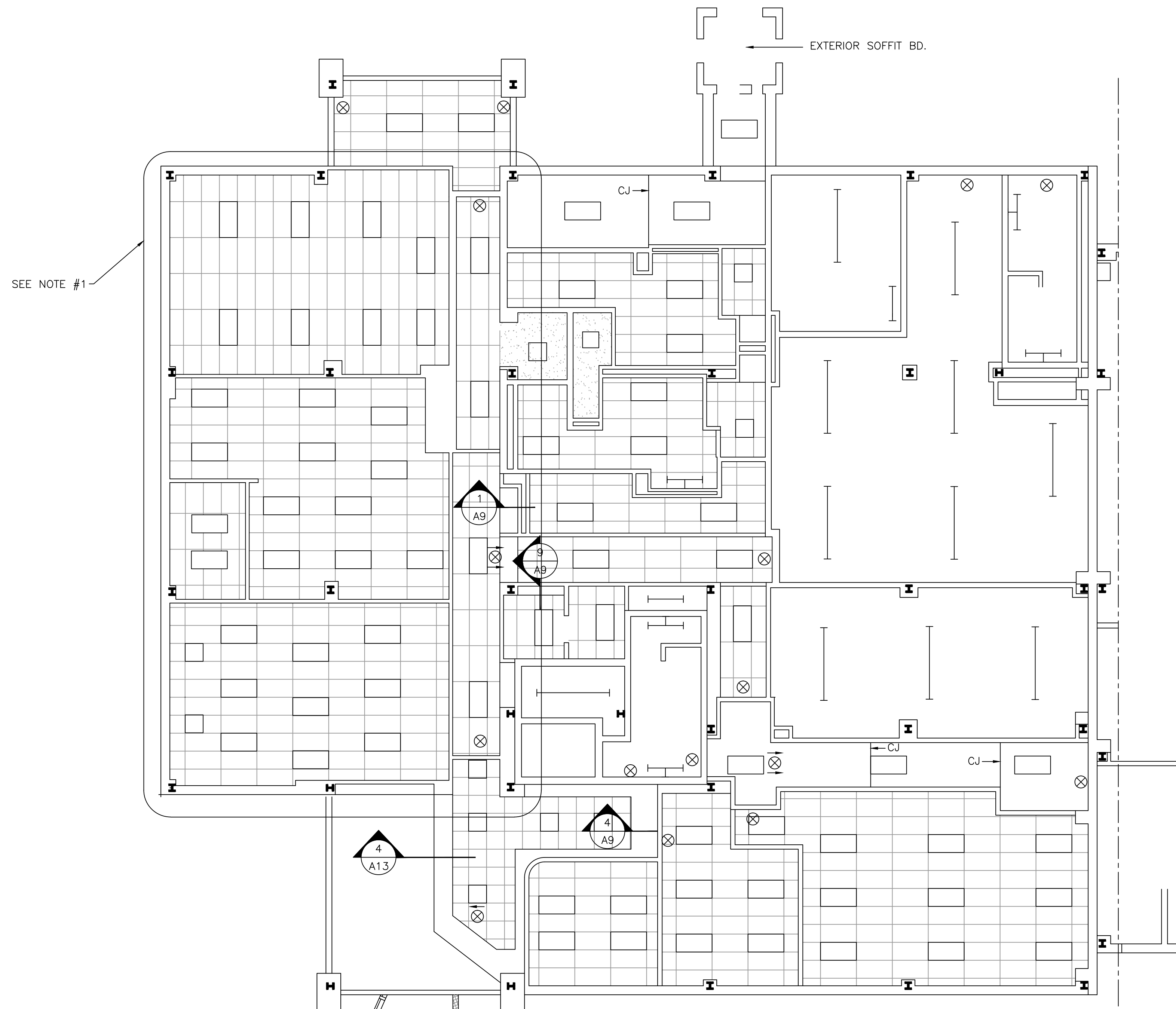

SEE DWGS A-19
THROUGH A-22 &
S-3/S-5/S-6 FOR
DETAILS

FIRST FLOOR CEILING PLAN - PART A
1/8" = 1'-0"

- NOTES:
- REFER TO DISPATCH AND OPERATORS LOUNGE RENOVATION PROJECT FILES FOR DETAILS.

SECOND FLOOR CEILING PLAN - PART A
1/8" = 1'-0"

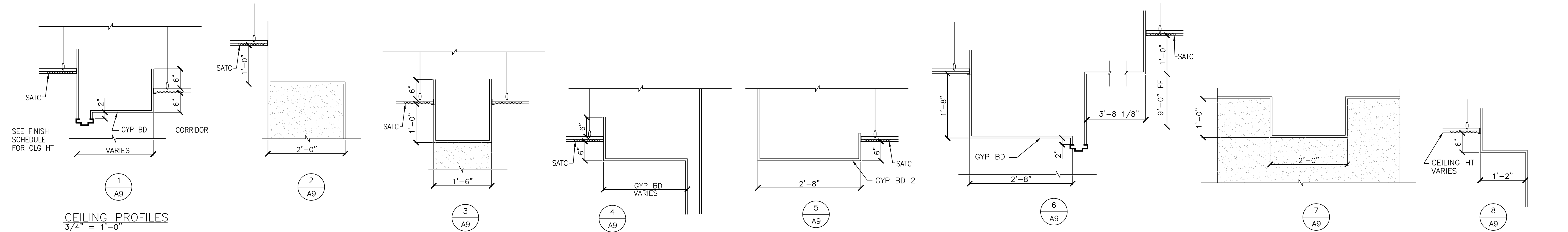

Symbol	Description	Initials	Date
1	Revised As-Built	PEO	9/15/06
	See Disclaimer Sheet 1 (Index sheet)		

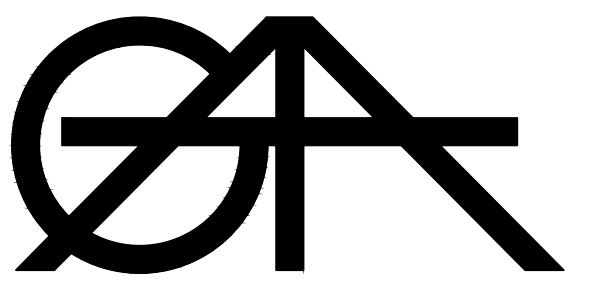

Gauthier, Alvarado & Associates, Inc.

Architecture Engineering Planning

PROJECT TITLE

PRTC

POTOMAC AND RAPPAHANNOCK
TRANSPORTATION COMMISSION

MULTI-PURPOSE TRANSIT CENTER

TRANSPORTATION CONSULTANTS:
SG Associates, Inc.

SITE ENGINEERS:
Springfield Engineering
Corporation, P.C.

PLANNING LANDSCAPE AND
SIGNAGE CONSULTANTS:
Collin & Collin

REVISIONS

NO.	DATE	DESCRIPTION
3-11-96		PRINT FOR BID
7-20-98		RECORD DWGS

DRAWN

CHECKED

DRAWING TITLE

ARCHITECTURAL FIRST FLOOR CEILING PLAN-PART B

DATE 1-15-96

DRAWING NUMBER

A-10

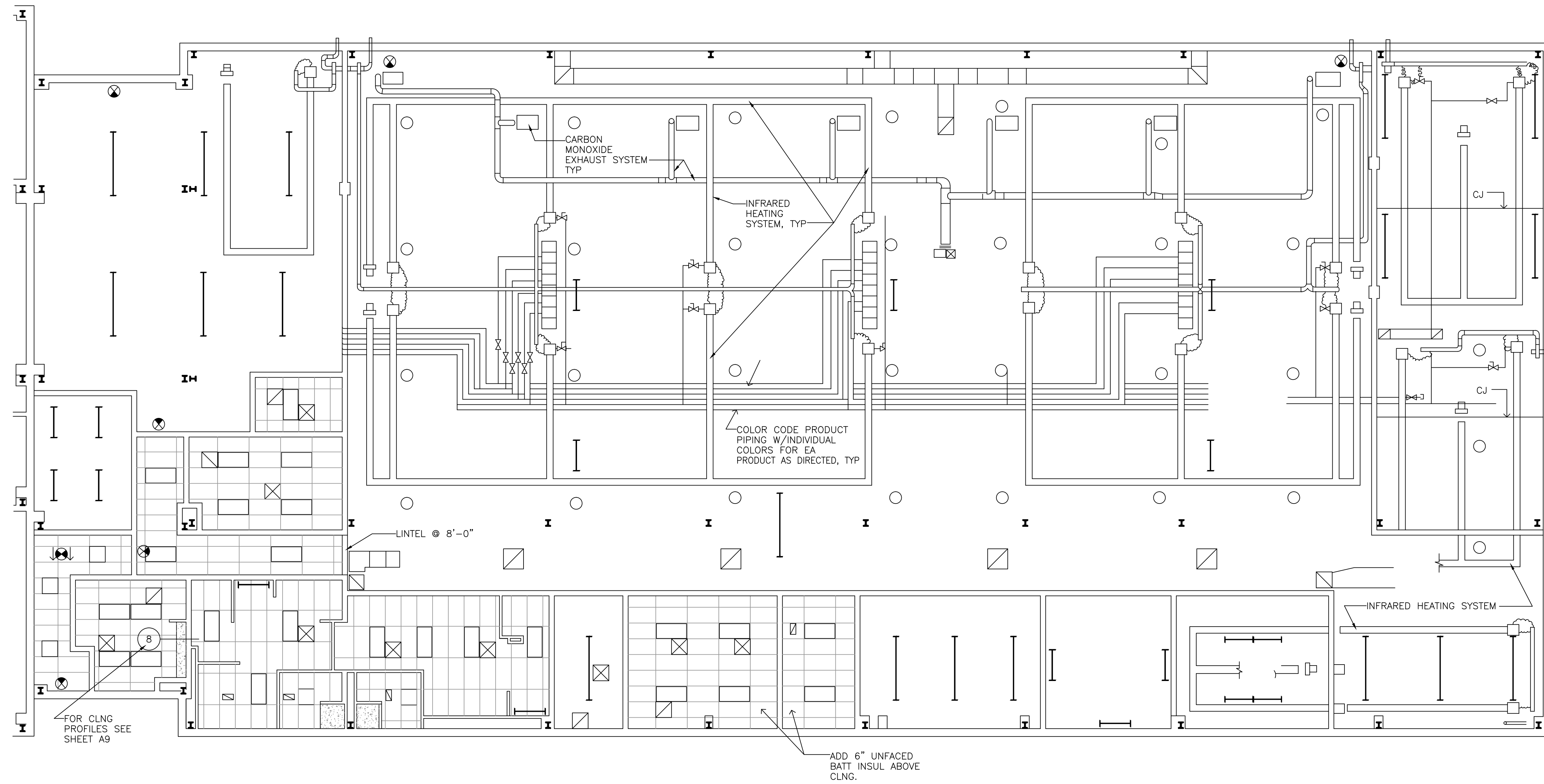

FIRST FLOOR REFLECTED CEILING PLAN-PART B
1/8" = 1'-0"

SYMBOLS

- DIFFUSER OR GRILLE
- LIGHT FIXTURE
- EXIT LIGHT

Symbol	Description	Initials	Date
	Revised As-Built	PEO	9/15/06
	See Disclaimer Sheet 1 (Index sheet)		

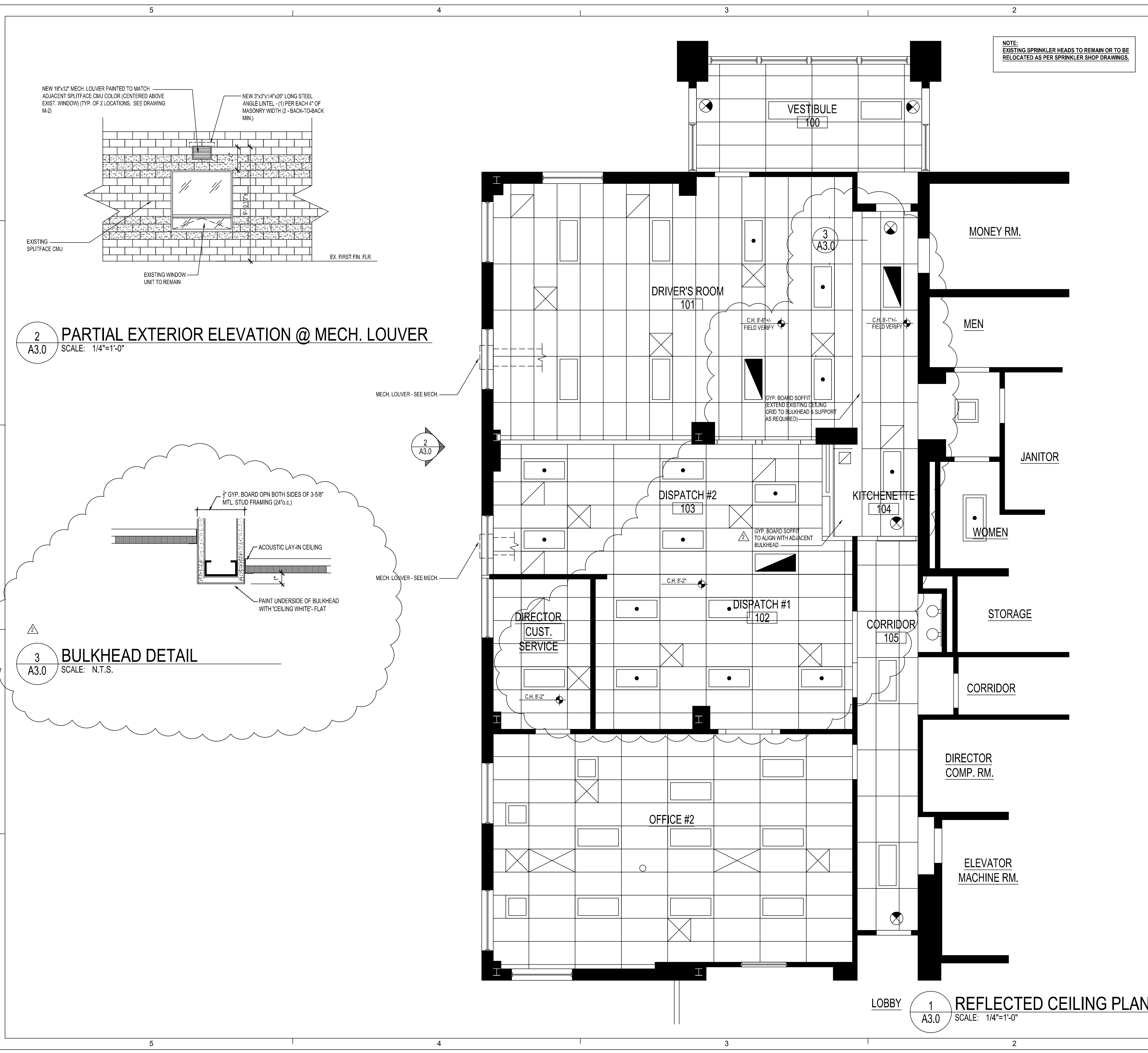

NOTE:
EXISTING SPRINKLER HEADS TO REMAIN OR TO BE RELOCATED AS PER SPRINKLER SHOP DRAWINGS.

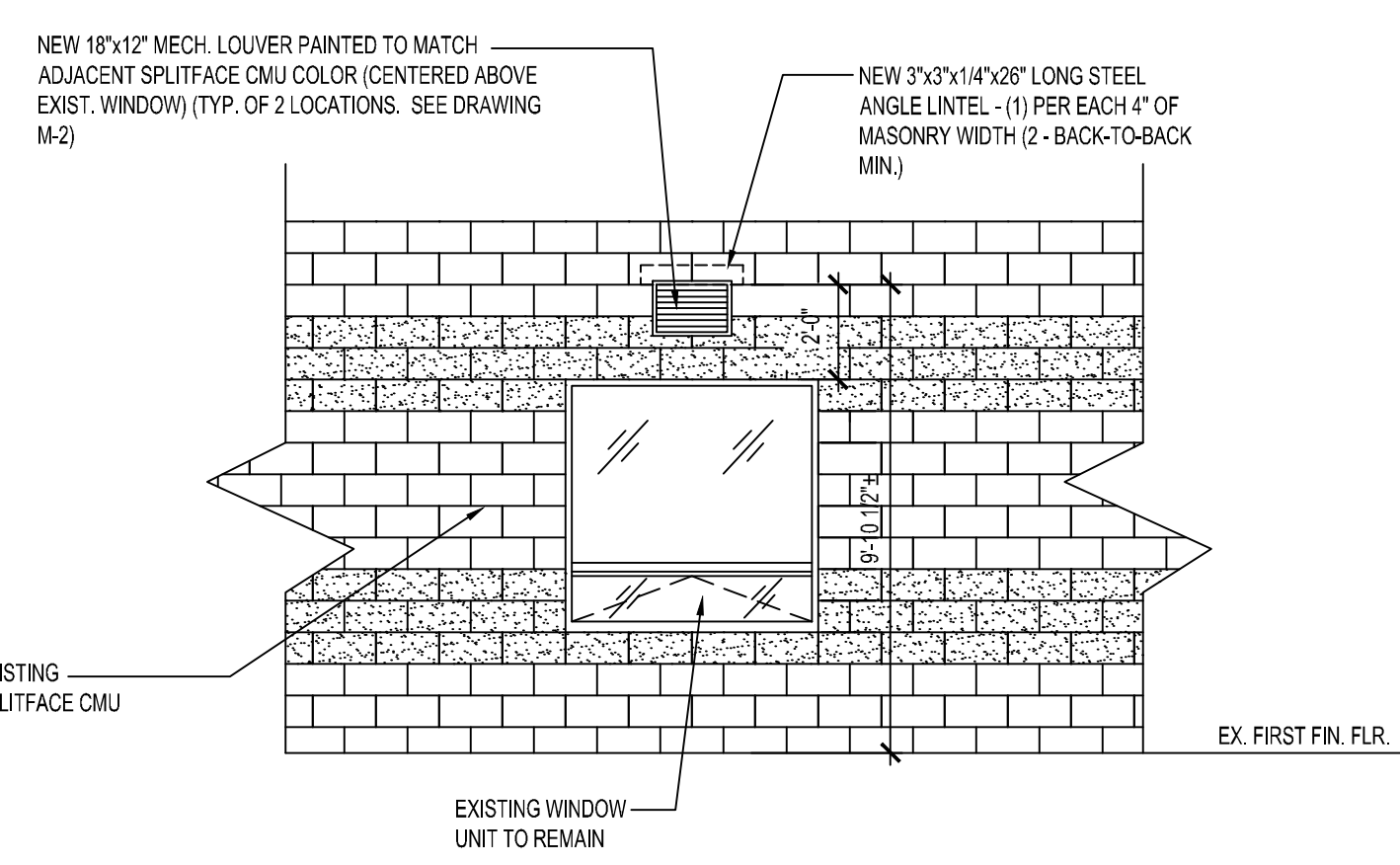

2 PARTIAL EXTERIOR ELEVATION @ MECH. LOUVER
SCALE: 1/4"=1'-0"

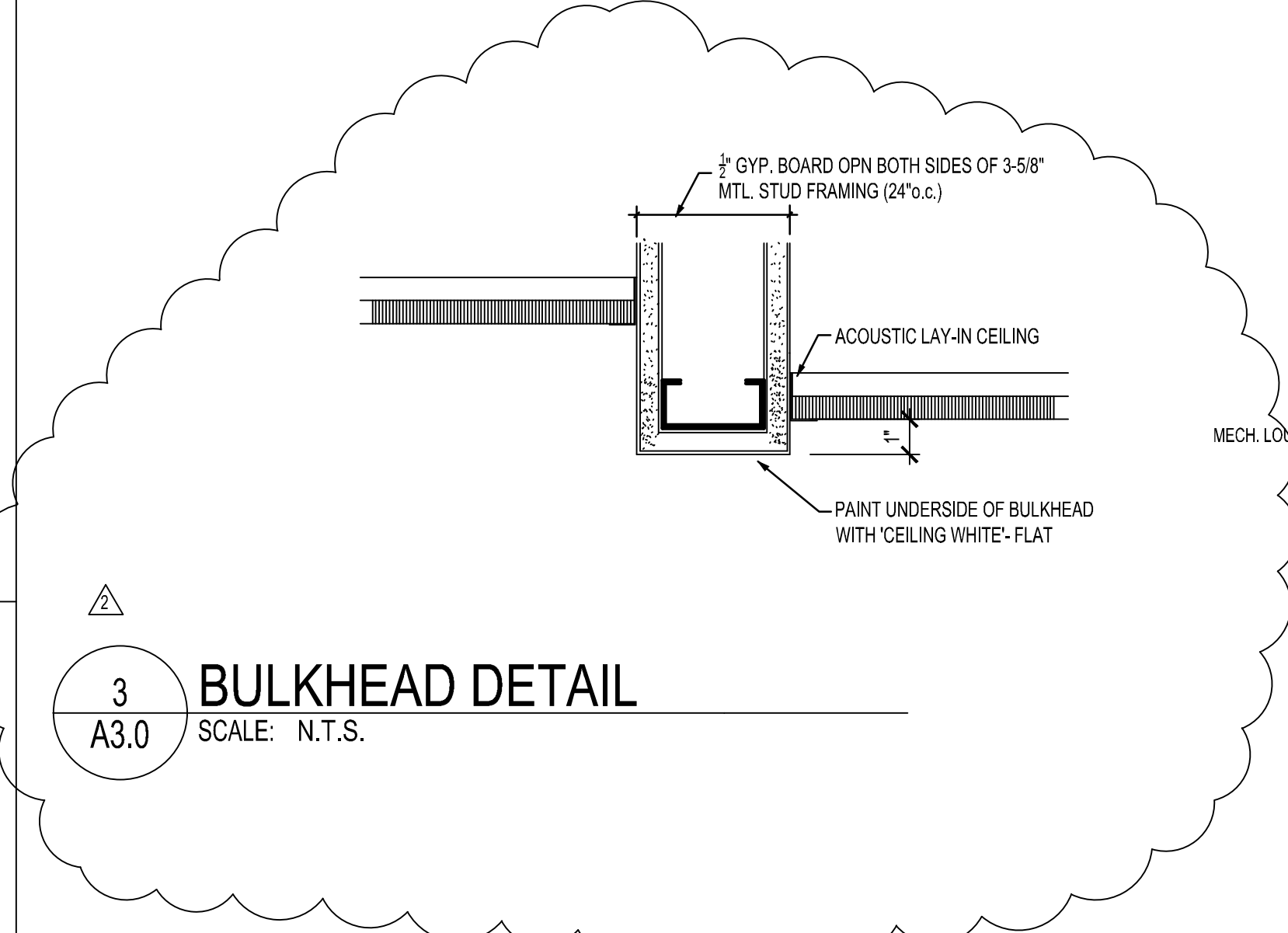

3 BULKHEAD DETAIL
SCALE: N.T.S.

1 REFLECTED CEILING PLAN
SCALE: 1/4"=1'-0"

NOTES:
 PROVIDE FOR COMPLETE INSTALLATION OF LIGHT FIXTURES, INCLUDING HOUSINGS, TRIM, ASSOCIATED WIRING, SWITCHING, ETC.
 PROVIDE COMPREHENSIVE SUBMITTAL TO ARCHITECT FOR APPROVAL FOR ALL LIGHTS.
 CONFIRM / COORDINATE BUILDING STANDARD FOR ALL 2 X 4 FLUORESCENT LIGHT FIXTURES WITH OWNER AND ARCHITECT. SEE E-1 & E-2 FOR NEW FIXTURE SPEC. & LOCATION.
 COORDINATE HEIGHT OF SUSPENDED LIGHTS WITH ARCHITECT.

DRAWING LEGEND

- EXISTING PARTITION / CONSTRUCTION TO REMAIN
- NEW DRYWALL PARTITION
- 2X4 FLUORESCENT LIGHT FIXTURE
- EMERGENCY LIGHT
- EXIST'G 2X4 FLUORESCENT LIGHT FIXTURE (TO REMAIN/RELOCATED)
- EXIST'G 2X2 FLUORESCENT LIGHT FIXTURE (TO REMAIN)
- ROOM NAME
- KEYED NOTES TO PLAN - SEE EACH SHEET FOR NOTES OR SPECIFICATION ITEMS
- EXIT SIGN
- SUPPLY - SEE MECHANICAL
- RETURN - SEE MECHANICAL

CEILING NOTES
(SEE DRAWING SHEET E-2 FOR LIGHTING SPECIFICATIONS)

SHOULD A CONFLICT OCCUR BETWEEN THE ARCHITECTURAL AND ENGINEERING DRAWINGS, THE CONTRACTOR SHALL CONTACT THE ARCHITECT FOR RESOLUTION.

CEILING SHALL BE TRUE, FLAT, STRAIGHT AND REGULAR. PROVIDE STABILIZER BARS AS REQUIRED TO DISTRIBUTE LOAD EQUALLY OVER TWO OR MORE RUNNERS.

INSTALL MAX. LENGTHS OF EDGE MOULDING AT INTERSECTION OF CEILING AND VERTICAL SURFACE. MITER ALL CORNERS, AT NEW CEILINGS.

COORDINATE INSTALLATION WITH ELECTRICAL, MECHANICAL AND SPRINKLER REQUIREMENTS.

LAY DIRECTIONAL PATTERN UNITS IN SINGLE DIRECTION. INSTALL CEILING TILE HOLD DOWN CLIPS AT PARTITIONS WITH CUT CEILING TILES, AT NEW CEILINGS.

ANY TEGULAR CEILING TILE TO BE CUT AND FITTED SNUG AGAINST PARTITIONS. DO NOT SHIM THE GRID TO ALLOW CEILING TILE TO PASS OVER TOP OF PARTITION.

LEVEL CEILING TO WITHIN 1/8" IN 12 FEET IN ANY DIRECTION. THIS INCLUDES EXISTING CEILINGS.

LEVEL WITH HANGER WIRE TAUT AND PLUMB, WITHOUT KINKING OR BENDING HANGER WIRES. CEILING HEIGHT SHALL MATCH EXISTING UNLESS NOTED OTHERWISE.

THE G.C. SHALL FIELD CHECK THE PREMISES AND VERIFY THAT THE CEILING LAYOUT SHOWN ON THE DRAWINGS CAN BE ACCOMMODATED AND VERIFY ALL CLEARANCES AS REQUIRED FOR ALL LIGHTING FIXTURES, DUCT WORK AND SPRINKLERS BEFORE PROCEEDING WITH ANY INSTALLATION. REPORT ANY DISCREPANCIES TO THE ARCHITECT PRIOR TO PROCEEDING.

THE G.C. SHALL VERIFY THAT ALL LIGHT FIXTURES CAN BE PLACED PER THE LIGHTING LAYOUT. REPORT ANY CONFLICTS TO THE ARCHITECT FOR RESOLUTION BEFORE PROCEEDING WITH ANY CEILING WORK.

THE G.C. IS TO PROVIDE SUBMITTALS OF SPECIFIED CEILING AND TRIM ACCESSORIES TO ARCHITECT FOR APPROVAL - NO SUBSTITUTIONS UNLESS AUTHORIZED BY ARCHITECT.

ALL PERIMETER MOULDING TO BE FLAT ANGLE MOULDING, TYPICAL, AND IS TO BE WHITE IN COLOR.

ALL FIXTURE TRIM (LIGHTING, SPEAKER, HVAC GRILLES, ETC.) SHALL BE METAL AND PAINTED TO MATCH ADJACENT CEILING FINISH. DO NOT USE PLASTIC TRIM.

CENTER NEW LIGHTS AND SPRINKLER HEADS IN ALL TILES.

EXISTING ACOUSTIC CEILING TILE TO BE POINTED UP, PATCHED AND REPAIRED AS REQUIRED BY DEMOLITION AND NEW CONSTRUCTION.

SPECIAL GC NOTE:
THE GC IS TO FORWARD ARCHITECTURAL CEILING PLAN TO ELECTRICAL SUBCONTRACTOR FOR BID AND LAYOUT PURPOSES - ARCHITECTURAL PLAN MAY BE MORE CURRENT THAN ELECTRICAL PLAN.



9110 Railroad Drive Suite 300
Manassas Park, Virginia 20111
Voice 703.530.1612
Fax 703.530.1615
www.dunningarchitects.com

PROJECT:
PRTC
Potomac and Rappahannock
Transportation Commission

PRINCE WILLIAM COUNTY,
VIRGINIA

OWNER:
PRTC

AT
14700 Potomac Mills Road
Woodbridge, VA 22192

CLIENT:

CONSULTANTS:

PROFESSIONAL SEAL:

ISSUED	DATE
BUILDING PERMIT	9-25-07

NO. REVISION	DATE
REVISION	JULY 03, 2008

DESIGNED/ DRAWN BY: _____
 REVIEWED/ APPROVED BY: _____
 PROJECT NO: 2007-022
 SCALE: _____

THIS DOCUMENT, AND THE IDEAS AND DESIGNS INCORPORATED HEREIN AS AN INSTRUMENT OF PROFESSIONAL SERVICE, IS THE PROPERTY OF DUNNING GROUP ARCHITECTS, LLC AND IS NOT TO BE COPIED OR USED, IN WHOLE OR IN PART FOR ANY OTHER PROJECT WITHOUT THE WRITTEN AUTHORIZATION OF DUNNING GROUP ARCHITECTS, LLC.

SHEET TITLE:
REFLECTED CEILING PLAN

SHEET NUMBER:
A3.0

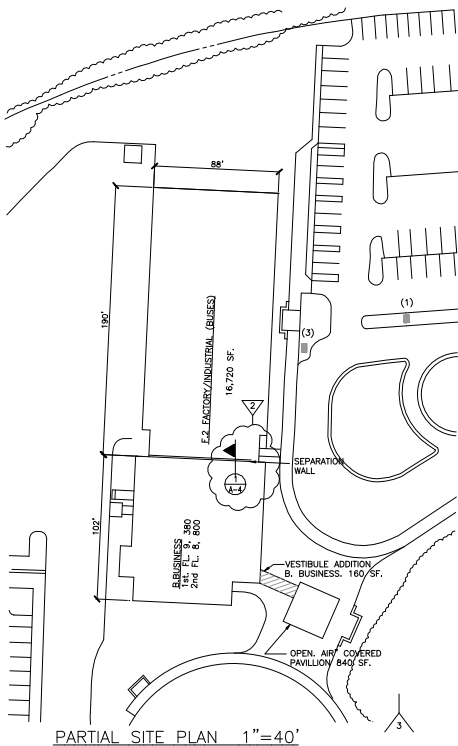

VESTIBULE IS IN COMPLIANCE WITH BOCA 96 SECTION 303.1-A "A ROOM OR SPACE USED FOR ASSEMBLY PURPOSES BY LESS THAN 50 PERSONS AND WHICH IS ACCESSORY TO ANOTHER USE GROUP SHALL BE INCLUDED AS A PART OF THAT MAIN USE GROUP." (B.)

THE VESTIBULE SHALL BE CONSIDERED AS A PORTION OF THE ORIGINAL BUILDING IN ACCORDANCE WITH BOCA'96 SECTION 503.1.3.-

TABLE 503-TYPE 2C SF PER FLR BUSINESS	= 14,400
SF B- (BUSINESS) FIRST FLR, ORIGINAL BLDG+VESTIBULE	= 9,540
SF THREE FLOORS ALLOWED-VESTIBULE IS 1 STORY.	

SECTION 1023.3 EXIT SIGNS AND LIGHTS

1023.1 LOCATION: IN ALL BUILDINGS, ROOMS OR SPACES REQUIRED TO HAVE MORE THAN ONE EXIT OR EXIT ACCESS, ALL REQUIRED MEANS OF EGRESS SHALL BE INDICATED WITH APPROVED SIGNS READING "EXIT," VISIBLE FROM THE EXIT ACCESS AND, WHERE NECESSARY SUPPLEMENTED BY DIRECTIONAL SIGNS IN THE EXIT ACCESS CORRIDORS INDICATING THE DIRECTION AND WAY OF EGRESS. ALL "EXIT" SIGNS SHALL BE LOCATED AT EXIT DOORS OR EXIT ACCESS AREAS, SO AS TO BE READILY VISIBLE. SIGN PLACEMENT SHALL BE SUCH THAT ANY POINT IN THE EXIT ACCESS SHALL NOT BE MORE THAN 100 FEET (30.480 M) FROM THE NEAREST VISIBLE SIGN. EXCEPTIONS

- "EXIT" SIGNS ARE NOT REQUIRED IN SLEEPING ROOM AREAS IN OCCUPANCIES IN USE GROUP 1-3.
- MAIN EXTERIOR EXIT DOORS WHICH ARE OBVIOUSLY AND CLEARLY IDENTIFIABLE AS EXITS ARE NOT REQUIRED TO HAVE "EXIT" SIGNS WHERE APPROVED.

1ST FL 9,380 SF
VEST. 160
PAVILION 840
TOTAL 10,380 SF
(LESS THAN ALLOWABLE, TABLE 503)

STRUCTURAL CALCULATIONS FOR POTOMAC & RAPPAHANNOCK TRANSPORTATION COMMISSION WOODBRIDGE, VA 22192

PECK PECK & ASSOCIATES, INC.
2050 OLD BRIDGE ROAD
WOODBRIDGE, VIRGINIA 22192

MARCH 14, 2003

ADVANCE ENGINEERS LTD.
6800 BACKLICK ROAD, SUITE 300
SPRINGFIELD, VA 22150

Revised As-Built	PEO	01/15/02
Symbol/Description	Initials	Date
See Disclaimer Sheet 1 (Index sheet)		

STRUCTURAL NOTES

DESIGN LIVE LOAD: 30 psf (Basic Ground Snow Load)

Slab On grade 100 psf

WIND: PER BOCA CODE, LATEST EDITION. (80 MPH)

V = 80 MPH
FV = 14.4
PSF = 1.0

EARTHQUAKE LOAD:

AV = 0.05
AA = 0.05
EXPOSURE GROUP = 1
PERFORMANCE CATEGORY = A
SITE CO-EFFICIENT = 1.0
STRUCTURAL SYSTEM TYPE - LOAD BEARING WALL SYSTEM
R = 6.5
CD = 4.0

THE STRUCTURE IS DESIGNED IN ACCORDANCE WITH BOCA BASIC NATIONAL BUILDING CODE/1996.

SOIL VALUE: SOIL BEARING VALUE ASSUMED TO BE 2000 PSF FOR FOOTINGS FOUNDED ON UNDISTURBED NATURAL SOIL OR CONTROLLED STRUCTURAL FILL.

FOUNDATIONS: BOTTOMS OF ALL FOOTINGS SHALL EXTEND A MINIMUM OF ONE FOOT INTO UNDISTURBED SOIL OR CONTROLLED COMPACTED FILL AND WHERE SUBJECT TO FROST ACTION, AT LEAST TWO FEET SIX INCHES BELOW FINISHED GRADE. ELEVATIONS SHOWN ARE TO TOPS OF FOOTINGS, AND ARE FOR ESTIMATING PURPOSES ONLY. FOOTING ELEVATIONS SHALL BE ADJUSTED AS REQUIRED TO SUIT FIELD CONDITIONS. BORING LOGS ARE ON FILE THE ARCHITECT'S OFFICE FOR REVIEW BY THE CONTRACTOR. ALL FOUNDATION WORK TO BE INSPECTED AND APPROVED BY A SOILS ENGINEER PRIOR TO POURING CONCRETE. ALL CONTROLLED COMPACTED FILL SHALL BE PLACED UNDER THE SUPERVISION OF A SOILS ENGINEER.

CONCRETE: ALL CONCRETE SHALL BE 3000 PSI AT 28 DAYS, EXCEPT SLAB ON GRADE TO BE 3500 PSI. ALL CONCRETE EXPOSED TO WEATHER SHALL BE AIR ENTRAINED @ 2.1%. ALL STRUCTURAL CONCRETE HAS BEEN DESIGNED BY THE ULTIMATE STRENGTH METHOD AND IN ACCORDANCE WITH THE PROVISIONS OF ACI 318-95. ALL CONCRETE TO BE NORMAL WEIGHT CONCRETE.

CONCRETE PROTECTION FOR REINFORCEMENT: REINFORCING BARS AND MESH TO HAVE A MINIMUM CONCRETE COVER AS FOLLOWS:
CONCRETE POURED AGAINST EARTH: 3".

FORMED CONCRETE EXPOSED TO WEATHER OR IN CONTACT WITH EARTH: 2" FOR BARS LARGER THAN #5
1-1/2" FOR #5 AND SMALLER BARS.

SLABS ON GRADE, UNLESS OTHERWISE NOTED, REINFORCEMENT IS TO BE 2" FROM TOP OF SLAB, WALLS: INSIDE FACE-1"; OUTSIDE FACE- 1-1/2".

REINFORCING STEEL: ALL REINFORCING STEEL SHALL CONFORM TO ASTM A-615, GRADE 60, WELDED.

ALL STRUCTURAL STEEL CONNECTIONS SHALL BE FULL FILLET WELDED UNLESS OTHERWISE NOTED. E70 ELECTRODES

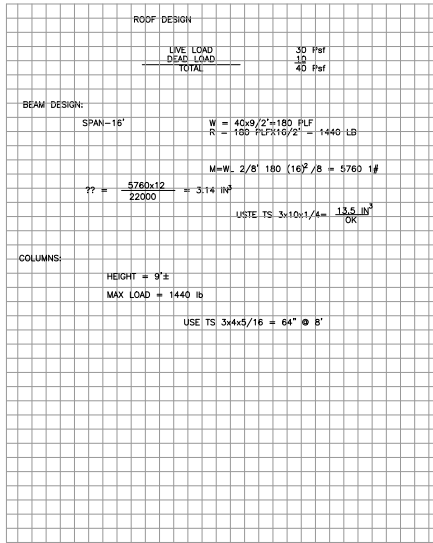

LOAD ANALYSIS

ELECTRICAL LOAD ANALYSIS (PER NEC 220)

L. LIGHTING

M. TOTAL CHANGE IN LIGHTING LOADS

N. RECEPTACLE LOADS

O. TOTAL CHANGE IN RECEPTACLE LOADS

P. MECHANICAL EQUIPMENT LOADS

Q. TOTAL CHANGE IN MECHANICAL LOADS

R. MISCELLANEOUS LOADS

S. TOTAL CHANGE IN MISCELLANEOUS LOADS

T. TOTAL LOAD: THE PROVISIONS OF NEC 220-36, THE SERVICE MUST HAVE CAPACITY TO SUPPORT 125 PERCENT OF THE DESIGN MAXIMUM DEMAND LOAD PLUS THE ADDITIONAL LOADS.

U. ADDITIONAL LOADS: THE PROVISIONS OF NEC 220-36, THE SERVICE MUST HAVE CAPACITY TO SUPPORT 125 PERCENT OF THE DESIGN MAXIMUM DEMAND LOAD PLUS THE ADDITIONAL LOADS.

V. TOTAL CALCULATED LOAD ON THE SERVICE IS

W. THE PROVISIONS OF NEC 220-36, THE SERVICE MUST HAVE CAPACITY TO SUPPORT 125 PERCENT OF THE DESIGN MAXIMUM DEMAND LOAD PLUS THE ADDITIONAL LOADS.

X. A TOTAL IMPACT OF 1740 AMPS ARE ADEQUATE FOR THE CALCULATED LOAD.

REFER TO REFL. CLG PLAN
SHT. A-1

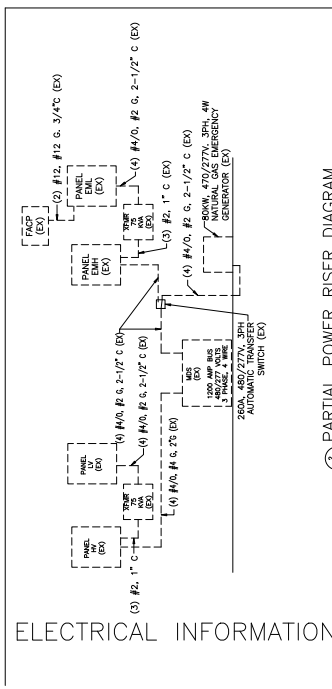

PARTIAL POWER RISER DIAGRAM
NOT TO SCALE

Panel Name	Voltage	Bus Rating	Description	Bar	Qty	Phase	Load in VA	Load in Amps
1	120/208	1000	TRANSFORMER	3/0	3	3	1,800	1,800
2	120/208	1000	TRANSFORMER	3/0	3	3	1,800	1,800
3	120/208	1000	TRANSFORMER	3/0	3	3	1,800	1,800
4	120/208	1000	TRANSFORMER	3/0	3	3	1,800	1,800
5	120/208	1000	TRANSFORMER	3/0	3	3	1,800	1,800
6	120/208	1000	TRANSFORMER	3/0	3	3	1,800	1,800
7	120/208	1000	TRANSFORMER	3/0	3	3	1,800	1,800
8	120/208	1000	TRANSFORMER	3/0	3	3	1,800	1,800
9	120/208	1000	TRANSFORMER	3/0	3	3	1,800	1,800
10	120/208	1000	TRANSFORMER	3/0	3	3	1,800	1,800
11	120/208	1000	TRANSFORMER	3/0	3	3	1,800	1,800
12	120/208	1000	TRANSFORMER	3/0	3	3	1,800	1,800
13	120/208	1000	TRANSFORMER	3/0	3	3	1,800	1,800
14	120/208	1000	TRANSFORMER	3/0	3	3	1,800	1,800
15	120/208	1000	TRANSFORMER	3/0	3	3	1,800	1,800
16	120/208	1000	TRANSFORMER	3/0	3	3	1,800	1,800
17	120/208	1000	TRANSFORMER	3/0	3	3	1,800	1,800
18	120/208	1000	TRANSFORMER	3/0	3	3	1,800	1,800
19	120/208	1000	TRANSFORMER	3/0	3	3	1,800	1,800
20	120/208	1000	TRANSFORMER	3/0	3	3	1,800	1,800
21	120/208	1000	TRANSFORMER	3/0	3	3	1,800	1,800
22	120/208	1000	TRANSFORMER	3/0	3	3	1,800	1,800
23	120/208	1000	TRANSFORMER	3/0	3	3	1,800	1,800
24	120/208	1000	TRANSFORMER	3/0	3	3	1,800	1,800
25	120/208	1000	TRANSFORMER	3/0	3	3	1,800	1,800
26	120/208	1000	TRANSFORMER	3/0	3	3	1,800	1,800
27	120/208	1000	TRANSFORMER	3/0	3	3	1,800	1,800
28	120/208	1000	TRANSFORMER	3/0	3	3	1,800	1,800
29	120/208	1000	TRANSFORMER	3/0	3	3	1,800	1,800
30	120/208	1000	TRANSFORMER	3/0	3	3	1,800	1,800
31	120/208	1000	TRANSFORMER	3/0	3	3	1,800	1,800
32	120/208	1000	TRANSFORMER	3/0	3	3	1,800	1,800
33	120/208	1000	TRANSFORMER	3/0	3	3	1,800	1,800
34	120/208	1000	TRANSFORMER	3/0	3	3	1,800	1,800
35	120/208	1000	TRANSFORMER	3/0	3	3	1,800	1,800
36	120/208	1000	TRANSFORMER	3/0	3	3	1,800	1,800
37	120/208	1000	TRANSFORMER	3/0	3	3	1,800	1,800
38	120/208	1000	TRANSFORMER	3/0	3	3	1,800	1,800
39	120/208	1000	TRANSFORMER	3/0	3	3	1,800	1,800
40	120/208	1000	TRANSFORMER	3/0	3	3	1,800	1,800
41	120/208	1000	TRANSFORMER	3/0	3	3	1,800	1,800
42	120/208	1000	TRANSFORMER	3/0	3	3	1,800	1,800
43	120/208	1000	TRANSFORMER	3/0	3	3	1,800	1,800
44	120/208	1000	TRANSFORMER	3/0	3	3	1,800	1,800
45	120/208	1000	TRANSFORMER	3/0	3	3	1,800	1,800
46	120/208	1000	TRANSFORMER	3/0	3	3	1,800	1,800
47	120/208	1000	TRANSFORMER	3/0	3	3	1,800	1,800
48	120/208	1000	TRANSFORMER	3/0	3	3	1,800	1,800
49	120/208	1000	TRANSFORMER	3/0	3	3	1,800	1,800
50	120/208	1000	TRANSFORMER	3/0	3	3	1,800	1,800
51	120/208	1000	TRANSFORMER	3/0	3	3	1,800	1,800
52	120/208	1000	TRANSFORMER	3/0	3	3	1,800	1,800
53	120/208	1000	TRANSFORMER	3/0	3	3	1,800	1,800
54	120/208	1000	TRANSFORMER	3/0	3	3	1,800	1,800
55	120/208	1000	TRANSFORMER	3/0	3	3	1,800	1,800
56	120/208	1000	TRANSFORMER	3/0	3	3	1,800	1,800
57	120/208	1000	TRANSFORMER	3/0	3	3	1,800	1,800
58	120/208	1000	TRANSFORMER	3/0	3	3	1,800	1,800
59	120/208	1000	TRANSFORMER	3/0	3	3	1,800	1,800
60	120/208	1000	TRANSFORMER	3/0	3	3	1,800	1,800
61	120/208	1000	TRANSFORMER	3/0	3	3	1,800	1,800
62	120/208	1000	TRANSFORMER	3/0	3	3	1,800	1,800
63	120/208	1000	TRANSFORMER	3/0	3	3	1,800	1,800
64	120/208	1000	TRANSFORMER	3/0	3	3	1,800	1,800
65	120/208	1000	TRANSFORMER	3/0	3	3	1,800	1,800
66	120/208	1000	TRANSFORMER	3/0	3	3	1,800	1,800
67	120/208	1000	TRANSFORMER	3/0	3	3	1,800	1,800
68	120/208	1000	TRANSFORMER	3/0	3	3	1,800	1,800
69	120/208	1000	TRANSFORMER	3/0	3	3	1,800	1,800
70	120/208	1000	TRANSFORMER	3/0	3	3	1,800	1,800
71	120/208	1000	TRANSFORMER	3/0	3	3	1,800	1,800
72	120/208	1000	TRANSFORMER	3/0	3	3	1,800	1,800
73	120/208	1000	TRANSFORMER	3/0	3	3	1,800	1,800
74	120/208	1000	TRANSFORMER	3/0	3	3	1,800	1,800
75	120/208	1000	TRANSFORMER	3/0	3	3	1,800	1,800
76	120/208	1000	TRANSFORMER	3/0	3	3	1,800	1,800
77	120/208	1000	TRANSFORMER	3/0	3	3	1,800	1,800
78	120/208	1000	TRANSFORMER	3/0	3	3	1,800	1,800
79	120/208	1000	TRANSFORMER	3/0	3	3	1,800	1,800
80	120/208	1000	TRANSFORMER	3/0	3	3	1,800	1,800
81	120/208	1000	TRANSFORMER	3/0	3	3	1,800	1,800
82	120/208	1000	TRANSFORMER	3/0	3	3	1,800	1,800
83	120/208	1000	TRANSFORMER	3/0	3	3	1,800	1,800
84	120/208	1000	TRANSFORMER	3/0	3	3	1,800	1,800
85	120/208	1000	TRANSFORMER	3/0	3	3	1,800	1,800
86	120/208	1000	TRANSFORMER	3/0	3	3	1,800	1,800
87	120/208	1000	TRANSFORMER	3/0	3	3	1,800	1,800
88	120/208	1000	TRANSFORMER	3/0	3	3	1,800	1,800
89	120/208	1000	TRANSFORMER	3/0	3	3	1,800	1,800
90	120/208	1000	TRANSFORMER	3/0	3	3	1,800	1,800
91	120/208	1000	TRANSFORMER	3/0	3	3	1,800	1,800
92	120/208	1000	TRANSFORMER	3/0	3	3	1,800	1,800
93	120/208	1000	TRANSFORMER	3/0	3	3	1,800	1,800
94	120/208	1000	TRANSFORMER	3/0	3	3	1,800	1,800
95	120/208	1000	TRANSFORMER	3/0	3	3	1,800	1,800
96	120/208	1000	TRANSFORMER	3/0	3	3	1,800	1,800
97	120/208	1000	TRANSFORMER	3/0	3	3	1,800	1,800
98	120/208	1000	TRANSFORMER	3/0	3			

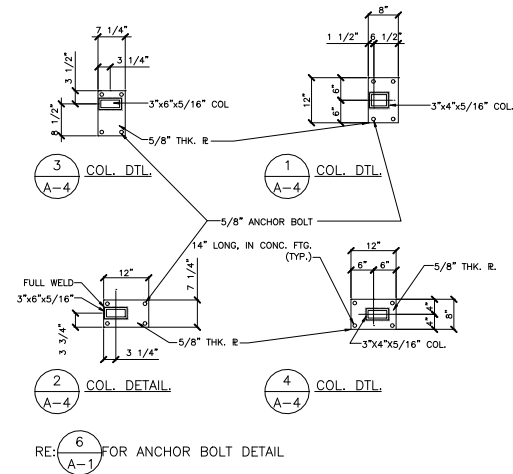
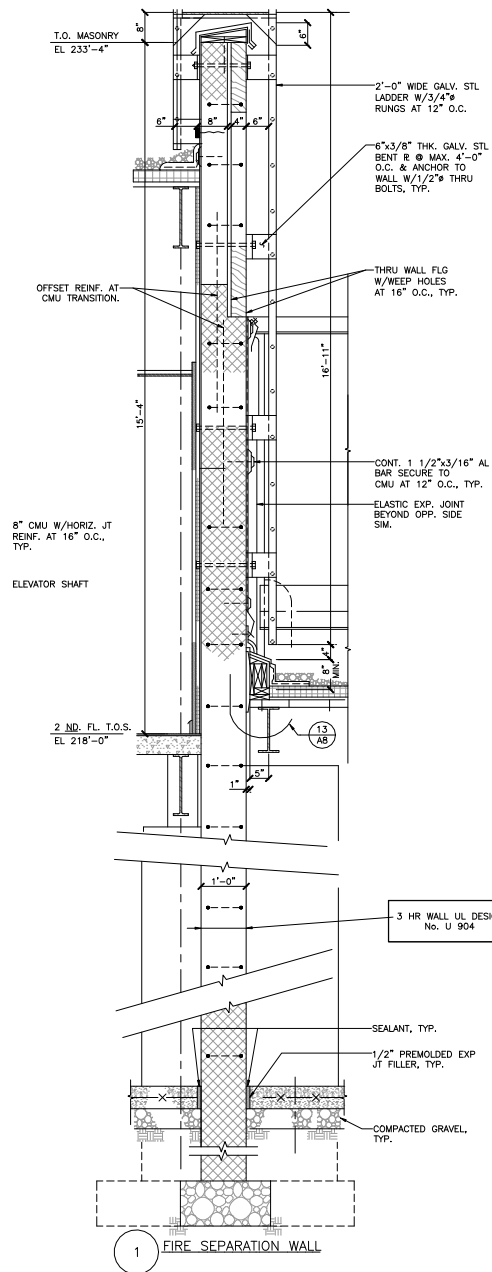

Revised As-Built	PEO
Symbol/Description	Initials/Date
See Disclaimer Sheet 1 (Index sheet)	

POTOMAC & RAPPAHANNOCK TRANSPORTATION COMMISSION
 14700 POTOMAC MILLS ROAD
 WOODBRIDGE, VA. 22192
 PECK, PECK & ASSOCIATES, INC.
 2050 OLD BRIDGE RD.
 WOODBRIDGE, VA. 22192

REVISION:
 5-10-03
 SEAL

SHEET
A-1-4
 4 OF 4

POTOMAC RAPPAHANNOCK TRANSPORTION COMMISSION
 14700 POTOMAC MILLS ROAD WOODBRIDGE, VA 22/92
 SHOP DRAWINGS PR-1 BY S. ROBINSON 3/10/03
 703-441-2699

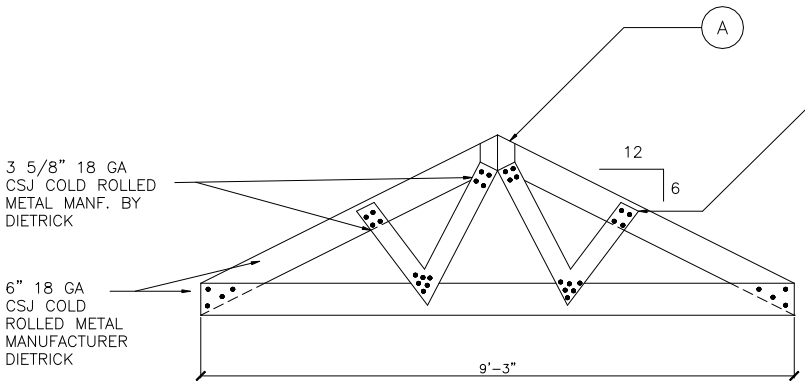

TRUSS
 3/4" = 1'

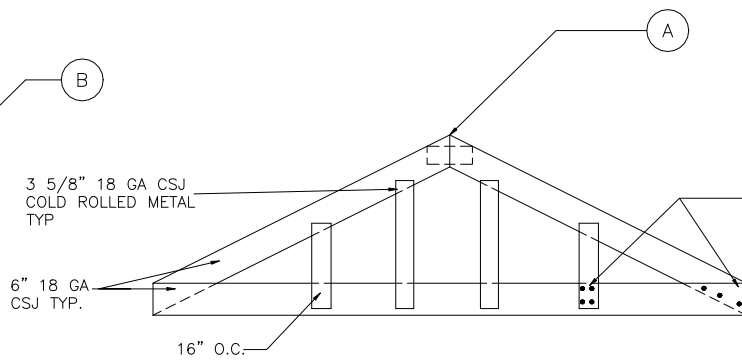

GABLE END
 3/4" = 1'

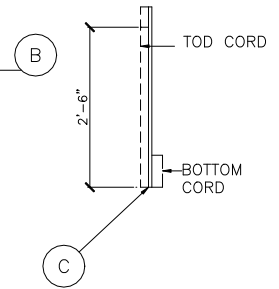

SIDE VIEW
 3/4" = 1'

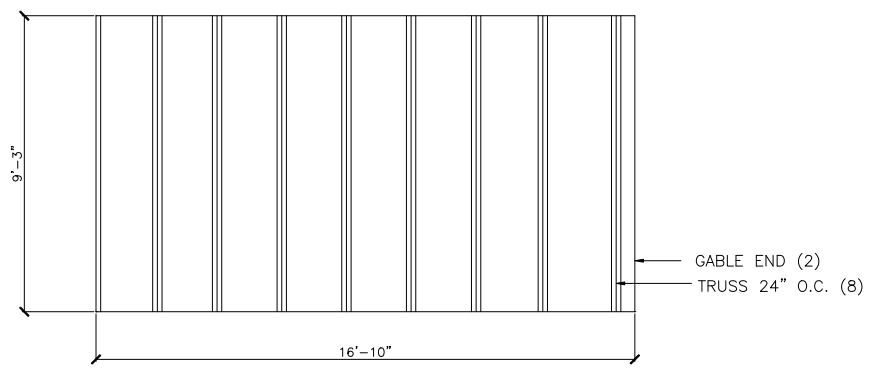

TOP VIEW
 3/8" = 1'

- _A: TOP CORD FASTENED AT APEX USING 4"x6" 18 GA MEUDING PLATE SECURE W/ (4) NO #10 SCREWS EA. SIDE
- _B: ALL FRAMING MEMBERS TO BE JOINED USING (4) NO # 10 SCREWS UNLESS SHOWN OTHERWISE.
- _C: BOTTOM CORD FASTENED TO BEAM USING CLIP ANGLE & SECRED W/(4) NO #10 SCREWS.
- _D: ALL METAL TO BE 18 GA. AS MANUFACTURED BY DIETRICK INDUSTRIES.

CONSTRUCTION NOTES

SHEET
 A-1-5

Symbol	Description	Initials	Date
▲	Revised As-Built	PEO	9/15/06
See Disclaimer Sheet 1 (Index sheet)			

ATTACHMENT B PRICING SCHEDULE

PRTC CEILING TILE AND GRID REMOVAL AND REPLACEMENT PRTC PRICING SCHEDULE				
Pricing shall be based on services outlined in the SOW.				
NAME OF BIDDER OR CONTRACTOR:			SOLICITATION NUMBER:	
			IFB No. 025-002	
SCOPE OF WORK				
The Potomac and Rappahannock Transportation Commission (PRTC) is soliciting bids from qualified companies to remove and replace existing ceiling grid and tile in the same configuration at its Transit Center located at 14700 Potomac Mills Road, Woodbridge, Virginia 22192.				
Item No.	ITEM DESCRIPTION	QUANTITY	UNIT PRICE	TOTAL PRICE
001	Mobilization/Site Prep (including moving furniture)	1		
002	Demolition and Material Disposal	1		
003	Materials for Installation of Ceiling Grid and Tile	1		
004	Labor for Installation of Ceiling Grid and Tile	1		
005	Additional Ceiling tiles (to remain onsite for future use)	48		
	TOTAL PRICE			

Print Name of Authorized Official: _____

Signature of Authorized Official: _____

Title of Authorized Official: _____

Date: _____

**ATTACHMENT C
REFERENCE FORM**

Describe previous work experience for at least five (5) engagements that are similar in-service type, size, scope, and/or complexity in the past five (5) years. Information shall include, but is not limited to, the following.

Client Company's Name _____

Contact Name _____ Telephone Number _____

Fax Number _____

Address _____

Type of business, if not public transportation _____

Detailed scope of services

Beginning and ending dates _____

Contract value \$ _____

Other information:

ATTACHMENT D IFB SUBMISSION FORM

Bids Due: **December 3, 2024**

IFB Number: **#025-002**

Name of IFB: **PRTC Ceiling Tile and Grid Removal and Replacement**

SECTION I - COMPANY IDENTIFICATION AND OWNERSHIP DISCLOSURE

Company _____	Contact Person _____
Address _____	Title _____
_____	Telephone No. _____
Remittance Address _____	FAX No. _____
_____	Email _____

Indicate Which Apply:

Corporation Partnership Sole Proprietorship Small Business

Disadvantaged Business Enterprise (DBE) Certified by: _____

Organized under the laws of the State of _____ Age of Firm: _____ years
Principal place of business at _____

Annual gross Receipts: Indicate by checking X the appropriate block that applies to your firm:

Less than \$7,500,000 **More than \$7,500,000**

Following are the names and addresses of all persons having an ownership interest of 3% or more in the company: (Attach more sheets if necessary)

SECTION III - CONFLICTS OF INTEREST

This solicitation is subject to the provisions of Va. Code §§ 2.2-3100, *et seq.*, the "State and Local Government Conflicts of Interest Act."

The Bidder is **is not** aware of any information bearing on the existence of any potential organizational conflict of interest.

ATTACHMENT D (continued)
IFB SUBMISSION FORM

SECTION III - COLLUSION

I certify that this offer is made without prior understanding, agreement, or in connection with any corporation, firm, or person submitting an offer for the same services, materials, or equipment, and is in all respects fair and without collusion or fraud. I understand collusive bidding is a violation of the State and Federal law and results in fines, prison sentences, and civil damage awards. I hereby certify that the responses to the above representations, certifications, and other statements are accurate and complete. I agree to abide by all conditions of this Invitation for Bid and certify that I am authorized to sign for the Bidder.

Signature _____ Date _____

Name (Printed) _____ Title _____

BIDDER MUST RETURN THIS COMPLETED FORM WITH BID SUBMISSION

ATTACHMENT E INSURANCE REQUIRED CHECKLIST

X = Required Coverage, Indicate compliance in blank with Yes/No

		COVERAGE REQUIRED	LIMITS (FIGURES DENOTE MINIMUM)	
Yes	No*	Required		
___	___	X	1. Workers' Compensation and Employers' Liability; Admitted in Virginia	1. Statutory Limits of the Commonwealth of Virginia: Yes
___	___	X	Employer's Liability	\$500,000
___	___		All Sates Endorsement	
___	___		USL&H Endorsement	
___	___		Voluntary Compensation	
___	___	X	2. General Liability	2. \$1,000,000 Combined
___	___		Products	Single Limit Bodily
___	___	X	Complete Operations	Injury and Property
___	___	X	Contractual Liability	Damage Each Occurrence
___	___	X	Personal Injury	
___	___	X	Independent Contractors	
___	___		XCU Prop. Damage Excl.	
___	___	X	3. Automobile Liability	3. \$1,000,000 Combined
___	___	X	Owned, Hired & Rented	Single Limit Bodily
___	___		Motor Carrier Act End.	Injury and Property
				Damage Each Occurrence
___	___		4. Professional Errors and Omissions	4. \$1,000,000 Per Claim & Aggregate Limit
___	___		5. Garage Liability	5
___	___		6. Garage keepers' Legal Liability	6
___	___		7. Fire Legal Liability	
___	___		8. Other Insurance:	
___	___	X	9. PRTC named as additional insured on General Liability (This coverage is primary to all other coverage's PRTC may possess)	9
___	___	X	10. 30-day cancellation notice required	10
___	___	X	11. Best's Guide Rating - A:VI or Better, or Equivalent	11
___	___	X	12. The Certificate must state IFB #024-002 and IFB Title	12
___	___	X	13. Umbrella Liability	13 \$2,000,000 Limit per Occurrence

OFFEROR AND INSURANCE AGENT STATEMENT

We understand the Insurance Requirements of these specifications and will comply in full if awarded this Contract.

BIDDER

INSURANCE AGENCY

=====

SIGNATURE

SIGNATURE

BIDDER MUST RETURN THIS COMPLETED FORM WITH BID SUBMISSION

**ATTACHMENT F
SAMPLE CONTRACT**

**Potomac and Rappahannock
Transportation Commission
Services Contract**



CONTRACT: #025-002

SUBJECT: PRTC Ceiling Tile and Grid Removal and Replacement

Between:

Potomac and Rappahannock Transportation Commission, aka OMNIRIDE
14700 Potomac Mills Road
Woodbridge, VA 22192

and the Contractor:

This Contract is entered into this ____ day of _____, 2025, by and between the Potomac and Rappahannock Transportation Commission aka OMNIRIDE, or its authorized agents, and the Contractor identified above for supplies and services identified herein, on the following terms and conditions. This Contract is prepared in accordance with the Virginia Public Procurement Act, Va. Code §§ 2.2-4300, *et seq.*, which is incorporated herein by reference.

SECTION I

SPECIAL PROVISIONS

I.1 Definitions

“Potomac and Rappahannock Transportation Commission” or “PRTC” shall mean the Potomac and Rappahannock Transportation Commission authorized by the Virginia Public Procurement Act or other law to enter into contracts.

“Contract Administrator” - Matters relating to prices, terms and conditions, period of performance, qualities to be supplied, delivery schedule and financial adjustments shall be handled through the Contractor Administrator. The Contract Administrator for this Contract for PRTC is LaWana Glymph, Contract Specialist.

“Project Manager” (PM) assists in monitoring the work under the contract. The PM is responsible for the day-to-day clarifications and guidance of Contractor’s personnel as may be required under the Contract. The PM for this Contract is Miranda Hellem, Facility Project Manager.

“Contracting Officer” for this Contract is the PRTC Executive Director Dr. Bob Schneider (“PRTC Executive Director”/“Executive Director”).

“Contractor” shall mean:

whose authorized representative is _____, who is responsible for the performance obligation of the Contractor under this Contract.

I.2 Contract Term

The term of this Contract shall be until the successful completion of all work as outlined in the Scope of Work. The term of this Contract will begin upon execution of the Contract.

I.3 Incorporation of Documents

The following documents are hereby incorporated by reference into this Contract:

1. PRTC’s Solicitation Number IFB #025-002, entitled “PRTC Ceiling Tile and Grid Removal and Replacement,” and dated October 22, 2024.

2. Contractor’s Bid Response dated, _____.

I.3b Precedence of Terms

In the event of an inconsistency between the above-referenced documents, the inconsistency shall be resolved by the following order of precedence:

- a. The Virginia Public Procurement Act, Va. Code §§ 2.2-4300 et seq.
- b. PRTC Public Procurement Policy and Procedures Manual
- c. This executed Contract #025-002,
- d. Invitation for Bids, IFB No. 025-002, entitled, "PRTC Ceiling Tile and Grid Removal and Replacement," dated October 22, 2024.
- e. Contractor's Response dated, _____.

I.4 Provision of Services

The Contractor shall remove and replace the existing ceiling tile and grid at its Transit Center facility located at 14700 Potomac Mills Road, Woodbridge, VA 22192.

I.5 Contract Amount

In return for the services identified above, and subject to the "Non-Appropriation of Funds" clause herein, PRTC certifies that sufficient funds are budgeted and appropriated and shall compensate the Contractor for services outlined in Section III of the Scope of Work and at the rates outlined on the Pricing Schedule, which are attached to this contract.

I.6 Method of Payment

The Contractor shall submit invoices identifying the services performed. The invoice should cite the Purchase Order Number, Contract Number, and date of services.

PRTC will make payment to the Contractor, net 30 days or in accordance with discount terms, if offered, after receipt of an acceptable invoice.

I.7 Time of the Essence and Completion

Time shall be of the essence to this Contract, except where it is specifically provided to the contrary.

I.8 Key Personnel

The Contractor shall assign to this Contract the following key personnel:

During the period of performance, the Contractor shall make no substitutions of key personnel unless approved in writing by the Contract Administrator.

The Contractor shall provide a detailed explanation of the circumstances necessitating the proposed substitutions, complete resumés for the proposed substitutes, and any additional information requested by the Contract Administrator. Proposed substitutes should have comparable qualifications to those of the persons being replaced. The Contract Administrator will notify the Contractor within 15 calendar days after receipt of all required information of the decision on substitutions. This clause will be modified to reflect any approved changes of key personnel.

I.9 Insurance

The Contractor shall maintain insurance shall otherwise comply with the Insurance Requirements set forth in the following numbered paragraphs, plus the coverages and limits indicated on the "Insurance Checklist."

1. The Contractor shall be responsible for its work and every part thereof, and for all materials, equipment, and property of any and all description used in connection therewith. The Contractor assumes all risks of direct and indirect damage or injury to any person or property wherever located, resulting from any action, omission, commission, or operation under the Contract, or in connection in any way whatsoever with the Contract work.
2. The Contractor shall, during the continuance of all work under the Contract provide and agree to maintain Insurance Requirements as provided on the Insurance Checklist (**Attachment E**) and in Section III.15 of IFB No. 025-002, PRTC Ceiling Tile and Grid Removal and Replacement.

1.10 Hold Harmless, Indemnify, and Defend PRTC

The Contractor agrees to indemnify, defend at its own expense, and hold harmless PRTC, its officers, agents, employees, and volunteers, from any and all claims for property damage, bodily injuries, and personal injuries, including cost of investigation, all reasonable attorney's fees, and the cost of appeals arising out of any such claims or suits, because of any and all acts or omissions of the Contractor, including its agents, subcontractors, employees and volunteers, in connection with work under this Contract.

SECTION II

GENERAL PROVISIONS

II.1 Assignability of Contract

Neither this Contract, nor any part hereof, may be assigned by the Contractor to any other party without the prior express written permission of PRTC.

II.2 Modifications or Changes to the Contract

All modifications and changes to the Contract shall be in writing.

The PRTC Executive Director shall, without notice to any sureties, have the authority to order changes in this Contract which affect the cost or time of performance. Such changes shall be ordered in writing specifically designated to be a "Change Order." Such orders shall be limited to reasonable changes in the services to be performed or the time of performance; provided that the Contractor shall not be excused from performance under the changed contract by failure to agree to such changes, and it is the express purpose of this provision to permit unilateral changes in the Contract subject to the conditions and limitations herein.

The Contractor need not perform any work described in any change order unless it has received a certification from PRTC that there are funds budgeted and appropriated sufficient to cover the cost of such changes.

The Contractor shall make a demand for payment for completed changed work within 30 days of receipt of a change order, unless such time period is extended in writing, or unless the Executive Director requires submission of a cost proposal prior to the initiation of any changed work or supplies. Later notification shall not bar the honoring of such claim or demand unless PRTC is prejudiced by such delay.

No claim for changes ordered hereunder shall be considered if made after final payment in accordance with the Contract.

II.3 Employment Discrimination

1. During the performance of this Contract, the Contractor agrees as follows:

- a. The Contractor will not discriminate against any employee or applicant for employment because of race, religion, color, sex, sexual orientation, gender identity, national origin, age, disability, status as a service-disabled veteran, or any other basis prohibited by state law relating to discrimination in employment, except where there is a bona fide occupational qualification reasonably necessary to the normal operation of the

Contractor. The Contractor agrees to post in conspicuous places, available to employees and applicants for employment notices setting forth the provision of this nondiscrimination clause.

b. The Contractor, in all solicitations or advertisements for employees placed by or on behalf of the Contractor, will state that such Contractor is an equal opportunity employer.

c. Notices, advertisements, and solicitations placed in accordance with Federal law, rule, or regulation shall be deemed sufficient for the purpose of meeting the requirements of this section.

2. The Contractor will include the provisions of the foregoing paragraphs a, b, and c in every subcontract or purchase order over \$10,000, so that the provisions will be binding upon each subcontractor or contractor.

II.4 Drug-free Workplace to be Maintained by Contractor

During the performance of this Contract, the Contractor agrees to (i) provide a drug-free workplace for the Contractor's employees; (ii) post in conspicuous places, available to employees and applicants for employment, a statement notifying employees that the unlawful manufacture, sale, distribution, dispensation, possession, or use of a controlled substance or marijuana is prohibited in the Contractor's workplace and specifying the actions that will be taken against employees for violations of such prohibition; (iii) state in all solicitations or advertisements for employees placed by or on behalf of the Contractor that the Contractor maintains a drug-free workplace; and (iv) include the provisions of the foregoing clauses in every subcontract or purchase order over \$10,000, so that the provisions will be binding upon each subcontract or contractor.

For the purposes of this section, "drug-free workplace" means a site for the performance of work done in connection with a specific Contract awarded to a Contractor in accordance with this chapter, the employees of whom are prohibited from engaging in the unlawful manufacture, sale, distribution, dispensation, possession, or use of any controlled substance or marijuana during the performance of this Contract.

II.5 Claims/Disputes

Contractual Disputes and Claims: In accordance with Va. Code § 2.2-4363, this provision shall be followed for consideration and handling of all disputes and claims by the Contractor under this Contract. Va. Code § 2.2-4365 is not applicable to this Contract. Under no circumstances is this section an administrative appeals procedure governed by Va. Code § 2.2-4365.

Notice of the intent to submit a claim setting forth the basis for any claim shall be submitted in writing within ten (10) business days after the occurrence or the event giving rise to the claim or within ten (10) business days of discovering the condition giving rise to the claim, whichever is

later. In no event shall any claim arising out of this Contract be filed after submission of the request for Final Payment by the Contractor.

Claims by the Contractor with respect to this Contract shall be submitted in writing in the first instance for consideration by the Contract Administrator. The decision of the Contract Administrator shall be rendered in writing within 30 calendar days from the receipt of the claim from the Contractor. If the Contractor is not satisfied with the decision or resolution of the Contract Administrator, the Contractor may file a formal dispute with regard to the claim with the PRTC Executive Director within 30 calendar days of the decision of the Contract Administrator. The Executive Director shall reduce his/her decision to writing and shall mail or otherwise furnish a copy of its decision to the Contractor within 30 days of the receipt of the claim from the Contractor. The decision of the Executive Director shall be final and binding.

Should any decision-maker designated under this procedure fail to make a decision on a claim within the time period specified, then the claim is deemed to have been denied by the decision-maker. Pending a final determination of a claim, the Contractor shall proceed diligently with the performance of the work under this Contract.

In accordance with the provisions of Va. Code § 2.2-4363, full compliance with the disputes and claim resolution procedure set forth in this Section shall be a precondition of the filing of any lawsuit by the Contractor against the Commission arising out of the Contract.

II.6 Termination for Convenience of the Potomac and Rappahannock Transportation Commission

The parties agree that PRTC may terminate this Contract, or any work or delivery required hereunder, from time to time either in whole or in part, whenever the PRTC Executive Director shall determine that such termination is in the best interests of PRTC.

Termination, in whole or in part, shall be affected by delivery of a Notice of Termination signed by the Executive Director or his designee, mailed or delivered to the Contractor, and specifically setting forth the effective date of termination.

Upon receipt of such Notice, the Contractor shall:

1. cease any further deliveries or work due under this Contract, on the date, and to the extent, which may be specified in the Notice;
2. place no further orders with any subcontractors except as may be necessary to perform that portion of this Contract not subject to the Notice;
3. terminate all subcontracts except those made with respect to Contract performance not subject to the Notice;

4. settle all outstanding liabilities and claims which may arise out of such termination, with the ratification of the Executive Director; and

5. use its best efforts to mitigate any damages which may be sustained by it as a consequence of termination under this clause.

After complying with the foregoing provisions, the Contractor shall submit a termination claim, in no event later than six (6) months after the effective date of its termination, unless an extension is granted by the Executive Director.

PRTC shall pay reasonable costs of termination, including a reasonable amount for profit on supplies or services delivered or completed. In no event shall this amount be greater than the original Contract price, reduced by any payments made prior to Notice of Termination and further reduced by the price of the supplies not delivered, or the services not provided. This Contract shall be amended accordingly, and the Contractor shall be paid the agreed amount.

In the event that the parties cannot agree on the whole amount to be paid to the Contractor by reason of termination under this clause, PRTC shall pay to the Contractor the amounts determined as follows, without duplicating any amounts which may have already been paid under the preceding paragraph of this clause:

1. With respect to all Contract performance prior to the effective date of Notice of Termination, the total of:

a. cost of work performed or supplies delivered;

b. the cost of settling and paying any reasonable claims as provided in subparagraph (4) above;

c. a sum as profit on (a) determined by the Executive Director to be fair and reasonable.

2. The total sum to be paid under (a) above shall not exceed the Contract price, as reduced by the number of payments otherwise made, and as further reduced by the Contract price of work or supplies not provided. In the event that the Contractor is not satisfied with any payments, which the Executive Director shall determine to be due under this clause, the Contractor may appeal any claim in accordance with the "Claims and Disputes" clause of this Contract.

The Contractor shall include similar provisions in any subcontract and shall specifically include a requirement that subcontractors make all reasonable efforts to mitigate damages which may be suffered. Failure to include such provisions shall bar the Contractor from any recovery from PRTC whatsoever of loss or damage sustained by a subcontractor as a consequence of termination for convenience.

II.7 Termination for Default

Either party may terminate this Contract, without further obligation, for the default of the other party or its agents or employees with respect to any agreement or provision contained herein.

II.8 Examination of Records

The Contractor agrees that PRTC, or any duly authorized representative, shall, until the expiration of three (3) years after final payment hereunder, have access to and the right to examine and copy any directly pertinent books, documents, papers and records of the Contractor involving transactions related to this Contract.

The Contractor further agrees to include in any subcontract for more than \$10,000 entered into as a result of this Contract, a provision to the effect that the subcontractor agrees that PRTC or any duly authorized representative shall, until the expiration of three (3) years after final payment under the subcontract, have access to and the right to examine and copy any directly pertinent books, documents, papers and records of such Contractor involved in transactions related to such subcontract, or this Contract. The term "subcontract" as used herein shall exclude subcontracts or purchase orders for public utility services at rates established for uniform applicability to the general public. The period of access provided herein for records, books, documents and papers which may relate to any arbitration, litigation, or the settlement of claims arising out of the performance of this Contract or any subcontract shall continue until any appeals, arbitration, litigation or claims shall have been finally disposed of.

II.9 Termination for Non-Appropriation of Funds

If funds are not appropriated for any succeeding fiscal year subsequent to the one in which this Contract is entered into, for the purposes of this Contract, then PRTC may terminate this Contract upon thirty (30) calendar days prior written notice to the Contractor. Should termination be accomplished in accordance with this Section, PRTC shall be liable only for payments due through the date of termination.

II.10 Payments to Subcontractors

In the event that the Contractor utilizes a subcontractor for any portion of the work under this Contract, the Contractor hereby agrees to:

1. The Contractor shall take one of the two following actions within seven (7) business days after receipt of amounts paid to the Contractor by PRTC for work performed by a subcontractor under the Contract.
 - a. Pay a subcontractor for the proportionate share of the total payment received from PRTC attributable to the work performed by that subcontractor under the Contract; or

b. Notify PRTC and any subcontractors, in writing, of its intention to withhold all or a part of the subcontractor's payment with the reason for nonpayment.

c. The prime contractor agrees further to return retainage payments to each subcontractor within seven (7) business days after subcontractor's work is satisfactorily completed. Work is satisfactorily completed when all the tasks called for in the subcontract have been accomplished and documented as required.

2. The Contractor shall be obligated to pay interest to a subcontractor on all monies owed by the Contractor that remain unpaid after seven (7) business days following receipt by the Contractor of payment from PRTC for work performed by a subcontractor under the Contract, except for amounts withheld under subsection 1.b. of this section. The Contractor's obligation to pay an interest charge to a subcontractor pursuant to the provisions of this section may not be construed as an obligation by PRTC. A contract modification may not be made for the purpose of providing reimbursement for any such interest charge. A cost reimbursement claim may not include any amount for reimbursement for such interest charge.

3. Unless otherwise provided under the terms of this Contract, interest shall accrue at the rate of one percent (1%) per month.

4. The Contractor is hereby required to include in each of its subcontracts a provision requiring each subcontractor to otherwise be subject to the same payment and interest requirements set forth in subsection 2 and 3 of this section with respect to each lower-tier subcontractor.

II.11 Ethics in Public Contracting

The Contractor hereby certifies that it has familiarized itself with Article 6 of Title 2.2 of the Virginia Public Procurement Act, Va. Code §§ 2.2-4367 through 2.2-4377, and that all amounts received by it, pursuant to this Procurement, are proper and in accordance therewith.

II.12 Governing Law and Forum

This Contract and any disputes hereunder shall be governed by the Constitution and laws of the Commonwealth of Virginia. Any legal action arising out of or related to this Contract shall be filed in a state court located in Prince William County, Virginia, or the United States District Court for the Eastern District of Virginia, Alexandria Division, to the exclusion of the courts of any other jurisdiction.

II.13 Integration

This Contract shall constitute the whole agreement between the parties. There are no promises, terms, conditions or obligations other than those contained herein, and this Contract shall supersede all previous communications, representations or agreements, written or verbal, between the parties hereto.

II. 14 Force Majeure

If either party to this Contract is rendered unable, wholly or in part, to carry out its obligations under this Contract in a timely manner by reason of some cause beyond the control and without the fault or negligence of the Party that amounts to Force Majeure, such party shall give to the other party prompt written notice within in five (5) business days thereof with reasonably full particulars, and if undisputed, the obligation of the party giving notice to perform its obligations shall be suspended during, but no longer than, the continuance of the Force Majeure, and such party shall act diligently to remove the Force Majeure as soon as practical and to reschedule the work or take such other action as is reasonable necessary to mitigate any delay.

For the purposes of this section, Force Majeure shall mean:

- (a) An act of way, whether or not declared, civil war, insurrection, riot, acts of terrorism, or any condition incident to the foregoing.
- (b) Acts of the Federal or State government or the entry of a court order, intended to, or having the effect of stopping or delaying the work.
- (c) An Act of God which for the purposes of this section shall mean an earthquake, flood, cyclone, or other cataclysmic phenomenon of nature or pandemic beyond the power of the party to foresee or make preparation in defense of. The performance of the work shall not be adjusted for normal inclement weather.

II.15 Immigration and Control Act of 1986

Pursuant to Va. Code § 2.2-43311.1, the Contractor certifies that it does not, and shall not during the performance of the Contract, knowingly employ an unauthorized alien as defined in the federal Immigration Reform and Control Act of 1986.



POTOMAC AND RAPPAHANNOCK
TRANSPORTATION COMMISSION

CONTRACTOR:

Executive Director/ Contracting Officer

Contractor Representative

Date

Title

Date

APPROVED AS TO FORM PRTC/OMNIRIDE ATTORNEY

Attorney's Signature

Date